



OWNER'S MANUAL

AVR-250
DIGITAL SURROUND
POWER AMPLIFIER

USAGE NOTICE

IMPORTANT SAFE MEASURE

Please obey the following caution to maintain the unit performance:

1. Away from the place with direct lighting, too high or too low temperature.
2. Away from moisture, dust and the place affected directly by speakers' vibration, especially avoid putting the unit on one of speakers.
3. Do not put the unit on the unstable place.
4. **Ventilation equipment**--- Its place and configuration should be set properly to assure enough ventilation. Therefore, bed, sofa, carpet or other coverings cannot be placed before it to avoid the open of the equipment, and the unit should be installed in well ventilated condition. Make sure to allow a space of 20cm (8inch) behind of the unit.
5. **Heat**---Away from heat source, such as caliduct, temperature recorder or other electric appliance.
6. It is the eligible maintaining worker who can do clean of inner components.
7. **Dumping liquid**---Keep objects or liquid from dropping or dumping into the unit through the holes.
8. **Damage needs maintaining service**---The unit should be maintained by the eligible personnel under the following conditions:
 - A. Power wire or plug is damaged
 - B. Object or liquid drops into the unit
 - C. The unit is caught in
 - D. The unit cannot be operated correctly or performance changes obviously.
 - E. The unit has been fallen down or the cabinet has been damaged.
9. **Maintaining service**---The user shouldn't repair the unit beyond the operation indication. You should consult the eligible personnel about all other maintaining service.



CAUTION:

1. Guarantee:

The serial number of this unit is printed on the back panel. You must tell the number, when you ask for compensation during the maintaining period.

2. AC fuse

The fuse in the cabinet is not optional by the user. If you cannot connect the power, please contact eligible maintaining service station.

3. Caution

Use the soft cloth to clean the front and back panel and cabinet. To dirtiness, use the soft cloth with detergent to scrape it off, then wipe it up with clean cloth. Do not use coarse cloth, thinner, alcohol or other chemicals, it maybe damage the coat or the letters on the panel.

4. Power source

Warning

Please read the following carefully before plugging the unit at the first time:

There are different power sources and voltages in different countries and regions. Please confirm if the normal voltage (AC 230V 50Hz) is accord with that in the using region.

5. Factory setup

Press RESET button in the remote commander, the system will re-start up, and all setup will recover the best one before leaving factory.

CONTENTS

USAGE NOTICE	1	POWER CONNECTOIN	14
IMPORTANT SAFE MEASURE	1	Power connection	14
CAUTION	1	SPEAKER SETUP	15
CONTENTS	2	Speaker configuration	15
BEFORE USING THE REMOTE		CHANNEL LEVEL SETUP	15
COMMANDER	3	BROADCASTING STATION PRESET ..	16
Battery Installation	3	When listen to FM/AM radio	16
Remote Commander Usage	3	When tuning to some station	16
FRONT PANEL FUNCTION	4	Broadcasting station setup	16
Front Panel	4	When selecting the preset station	16
Front Panel Display	4	SPECIFICATION.	17
REMOTE COMMANDER.....	7	TROUBLESHOOTING	18
BACK PANEL FUNCTION	8		
SYSTEM CONNECTION	10		
SPEAKER CONNECTION	11		
Perfect speaker composite	11		
Least speaker composite for playing surround sound	11		
Speaker placement	11		
Speaker connection	12		
Speaker cable connection	12		
ANTENNA CONNECTION	13		
Assembly of AM circle antenna	13		
AM antenna connection	13		
Incidental antenna connection	13		

BEFORE USING THE REMOTE COMMANDER

3

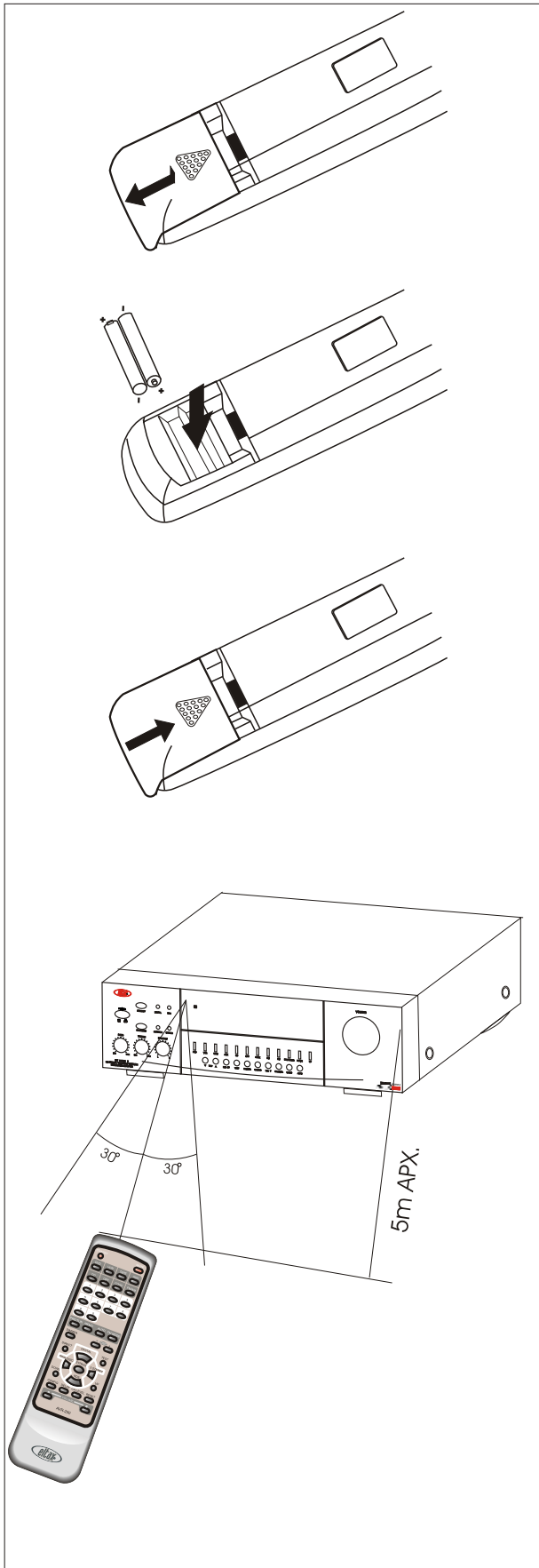

Battery Installation

1. Press and push the battery lid
2. Refer to the polarity sketch map (anode (+) and cathode (-)) inside the battery compartment and put two AAA batteries in it.
3. Close the battery lid after installing the batteries correctly.

Notes:

- * Avoid mixing new and old batteries or different types of batteries.
- * To avoid corrosion, remove the batteries if the remote commander will not be used for a long period of time.
- * To avoid corrosion a long damage, replace the weak battery. If the remote commander cannot work normally, replace both batteries with new ones.
- * Generally the use time of the incidental batteries is about 6 months, but the time is different under the different use conditions.

Remote Commander Usage

Make the remote commander point to the remote sensor. When receiving the signal from the remote commander, the unit will operate accordingly.

Notes:

- * Position the main unit away from direct lighting or strong lighting such as the inverter type of fluorescent lamp to avoid disturbing the remote commander's correct work.
- * It may cause operation disturbance that to use the same type of other remote commander or use the unit near the infrared equipment.
- * Do not put anything on the remote commander, otherwise, its button may be pressed correctly or waste batteries.
- * The shelf door cannot be made up of color glass. If you put the unit behind this kind of glass door, the remote commander may not work correctly.
- * There should be no any obstacles between the remote commander and the remote sensor.

FRONT PANEL FUNCTION

Front Panel

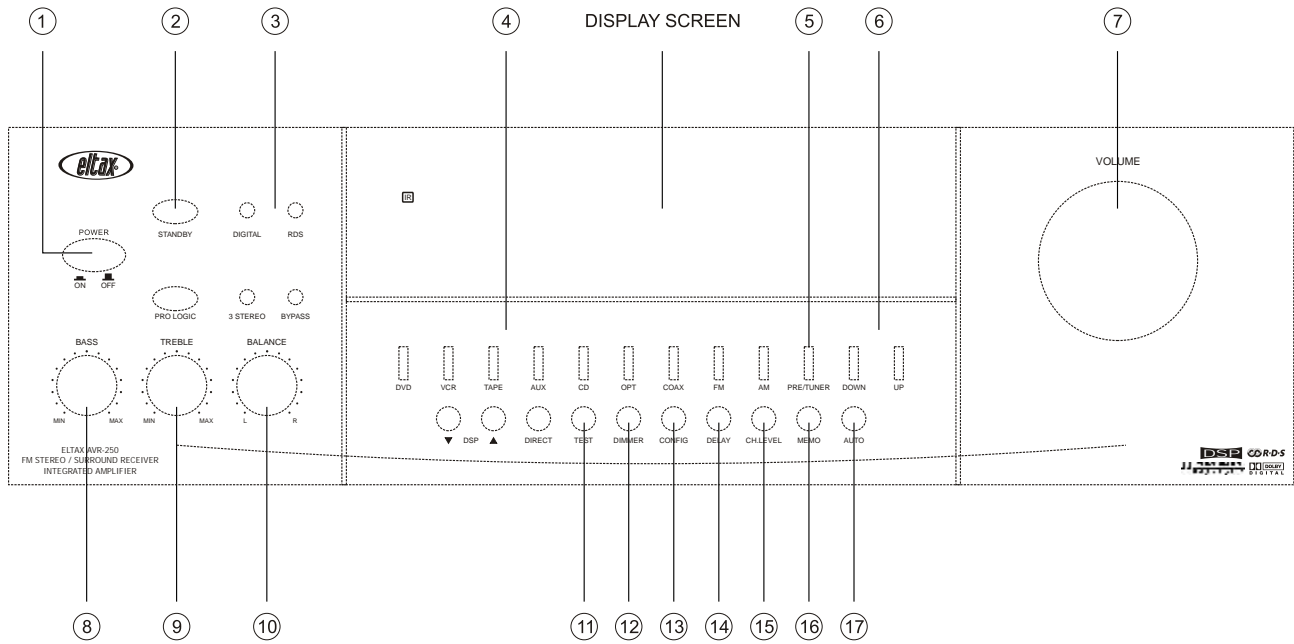

Front Panel Display

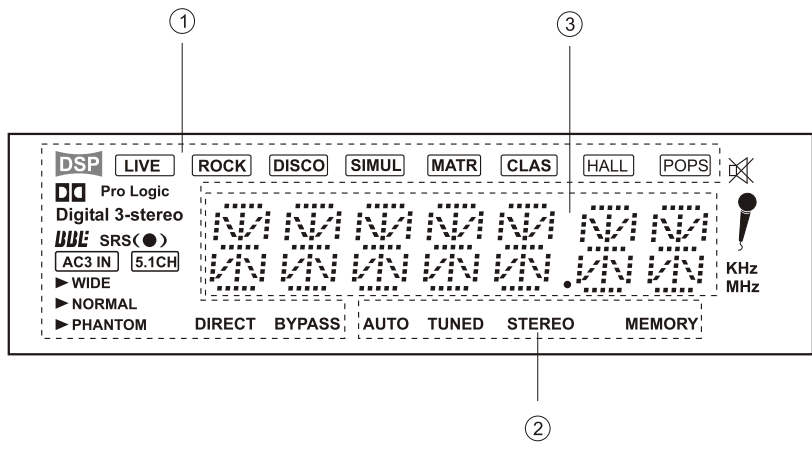

FRONT PANEL FUNCTION

Front Panel

1) POWER

After plugging in this unit, press Power button and the unit connects with the AC main power.

Be sure to all connections are completed before turn the main power on .

When turn on the unit, it may cause moment electrical surge and affect other electronic equipment in the same circuit. If so, please plug the unit in a different circuit.

2) STANDBY/ON

when press the button under the power on & the indicator light of standby will illuminate and the unit is in standby status. Under this status, the control functions lapse and all output is closed. Press the button again and enter the status before standby.

Note Under the standby status, the power doesn't cut off completely. If want to cut off it completely, you must turn POWER off or unplug the unit.

3) LISTEN MODE

Change listen mode by using these buttons.

A) Select DOLBY DIGITAL and BYPASS listen mode in the condition of DOLBY DIGITAL input.

B) Select RDS mode

C) Select PROLOGIC, 3 STEREO, BYPASS Listen mode in the condition of 2 channels DIGITAL input.

D) Select PROLOGIC, 3 STEREO, BYPASS or DSP listen mode in the condition of PCM or analog signal input. SELECT DIRECT listen mode in the analog condition.

E) DSP provides 8 kinds of sound effect, is LIVE, ROCK, DISCO, SIMUL, MATR, CLAS, HALL, POPS.

4) Input signal sources (DVD & VCR & TAPE & AUX & CD & OPT & COAX & FM & AM)

the button indicator light will illuminate, and the corresponding input source on the back panel is selected.

5) PRE/TUNER

When select AM or FM as input signal sources, press the button and can read the memorized radio stations, then choose the radio channel by using DOWN or UP. DOWN means the channel number decreasing and UP means the channel number increasing. When select AM or FM as input signal source, press the button, then adjust the tuner frequency by using DOWN or UP. DOWN means the tuner frequency decreasing and UP means the tuner frequency increasing.

6) DOWN/UP

The two buttons are multi-functional ones, and many other buttons should cooperate with them to complete adjustment.

7) VOLUME

Adjust the unit volume (UP or down of 6 channels) simultaneously.

8) BASS

It controls bass raising or depressing of left and right channels. The bass will raise by turning BASS knob CW and Vice versa.

9) TREBLE

It controls treble raising or depressing of left and right channels. The treble will raise by turning TREBLE knob CW and vice versa.

10) BALANCE

balance the left, right channel by turning the knob.

11) TEST

Test the volume of each sound channel by using the button (except DSP mode). Press the button and noise outputs from each channel, that is, left channel center channel right channel right surround channel left surround channel. Judge whether the whole system is balance according

FRONT PANEL FUNCTION

channel level setup. Press the button again and exit the noise test.

12;DIMMER

It is a brightness control of the display. There are four kinds of brightness for selection by pressing the DIMMER button.

13;CONFIG

In the mode of OPT or COAX, there will be DIGITAL display shown on the screen with the DOLBY digital signal input. Press CONFIG button to select L/R, C, sur L/R, SW then press DOWN or UP button to complete its configuration.

14;DELAY

Press the DELAY button to adjust the delay of surround channel and center channel. Press DOWN or UP button to select their delay time. But the center delay can not be selected in the case of non-5.1 channel digital signal input.

15;CH LEVEL

Select one from many channels and adjust the channel level in a small range ($\pm 10\text{dB}$). The button should be used with DOWN, UP button together.

16;MEMO

Memorize the radio stations selected by using the button, and the maximum memory is 30 radio channels. In the mode of AM or FM, press this button, the channel number and the station frequency will be shown on the display. At the same time, MEMORY on the display will flash for 5 times. The channel number to be memorized can be selected by using DOWN or UP. Press DOWN or UP button to store the station into the correspondent channel while MEMORY flashes.

17;AUTO

Search radio station automatically and memorize the results from the low channel to the high ch-

Front Panel Display

1;Listen Mode Display

2;Radio Display

3;Multi-function Display

REMOTE COMMANDER

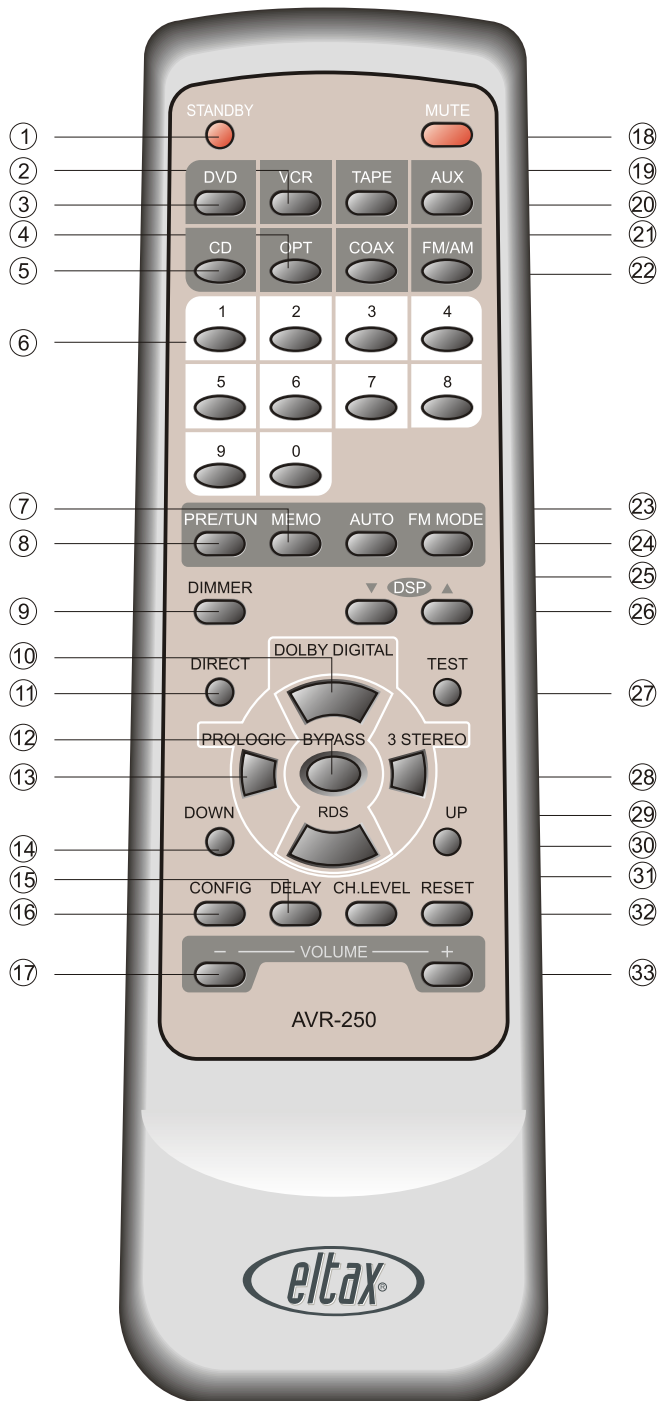

- ① STANDBY
- ② VCR
- ③ DVD
- ④ OPT
- ⑤ CD
- ⑥ 0-9
- ⑦ MEMO
- ⑧ PRE/TUN
- ⑨ DIMMER
- ⑩ DOLBY DIGITAL
- ⑪ DIRECT
- ⑫ BYPASS
- ⑬ PROLOGIC
- ⑭ DOWN
- ⑮ DELAY
- ⑯ CONFIG
- ⑰ VOLUME -
- ⑱ MUTE
- ⑲ TAPE
- ⑳ AUX
- ㉑ COAX
- ㉒ FM/AM
- ㉓ AUTO
- ㉔ FM MODE
- ㉕ DSP▼
- ㉖ DSP▲
- ㉗ TEST
- ㉘ 3 STEREO
- ㉙ RDS
- ㉚ UP
- ㉛ CH.LEVEL
- ㉜ RESET
- ㉝ VOLUME +

BACK PANEL FUNCTION

Herein they are the terminals of back panel and their usage. Before connecting audio and video components, read this section carefully and connect them according to the connection indication.

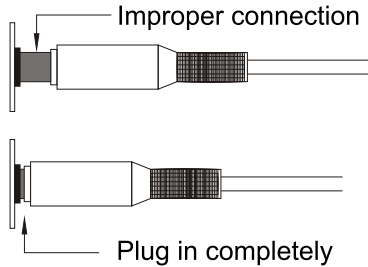

- * Refer to the manual when connecting the components.
- * Do not plug in the unit until all connections have been completed.
- * Regarding input jacks, the red (R mark) is for the right channel, the white (L mark) is for the left channel.
- * Connect all components stably and correctly, otherwise, wrong connection will cause noise, bad performance or equipment damage.
- * Do not bind audio cables, power wires and speaker cables together, otherwise, it has bad effect on the picture quality and timbre.

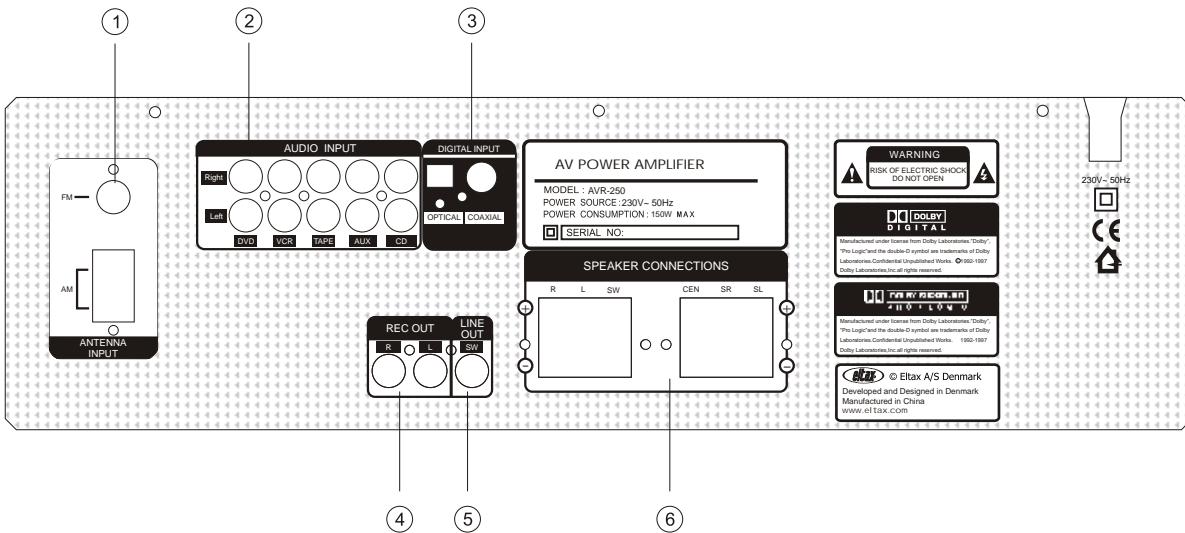

BACK PANEL FUNCTION

1;ANTENNA

For connecting FM indoor antenna and AM LOOP antenna.

2;AUDIO INPUT

These five terminals are analog audio signal input ports. The audio jacks have indicated the analog audio signal sources. RCA connection terminals must be used in audio input.

3;DIGITAL INPUT

These are two digital audio input ports. In optical input jack and In coaxial input jack, which receive

digital signal sources. When using the digital audio input ports, if possible, connect the analog terminal. When using the optical input jack, take off the protect cap and keep it properly. When the jack should not be used, please put on the protect cap.

4;REC OUT

Provide two channel audio signals for recording.

5;SW LINE OUT

It acts as the signal source of external sub-woofer amplification.

6;SPEAKER OUT

These are output terminals of speakers.

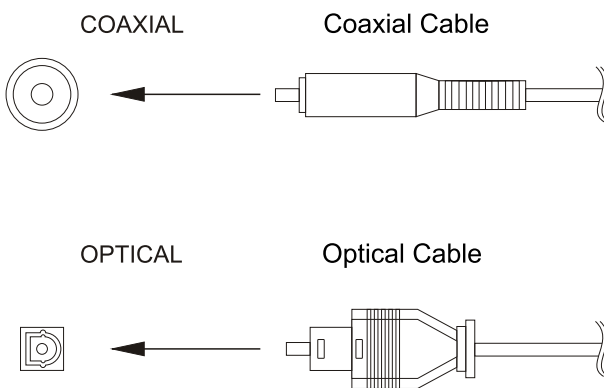

Optical Digital Input Terminal

The terminal is equipped with the protect cap. Take off the cap when connecting. No use, put it on the terminal.

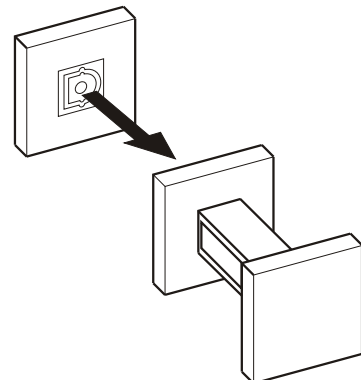

SYSTEM CONNECTION

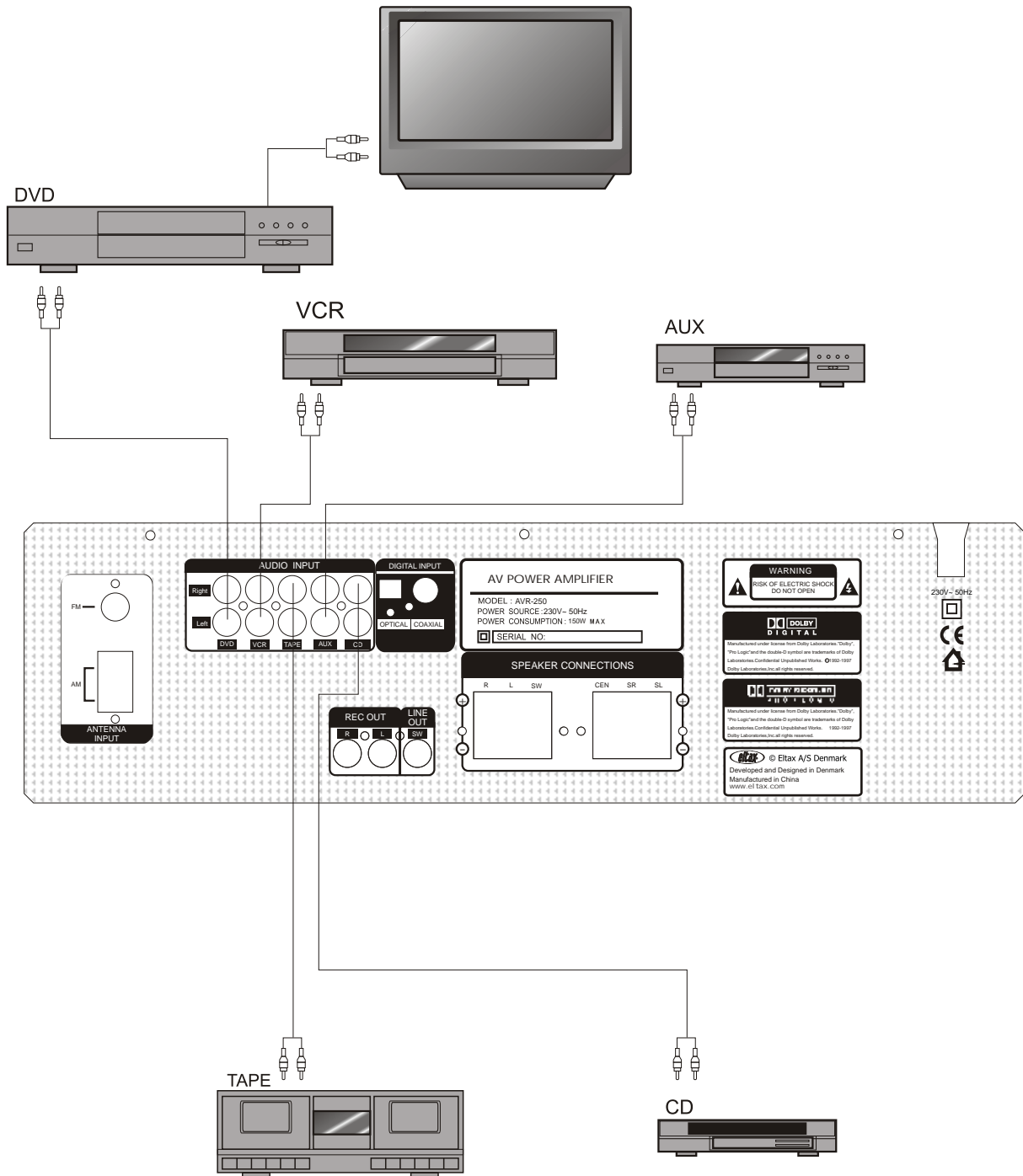

- * Refer to the manual when connecting the components.
- * Never plug in this unit until all connections are completed.
- * Input jacks: the red (R mark) is for right channel, the white (L mark) is for left channel.
- * Connect all components stably, otherwise, improper connection will cause noise, bad performance or equipment damage.
- * Do not bind the audio cables, power wires and speaker cables together, which will have bad effect on the sound.

SPEAKER CONNECTION

Before connecting speakers, please refer to the manual and place them properly. To surround sound, speaker configuration and place are very important.

Perfect Speaker Composite

- * Main speakers: left and right
- * Center speaker

When playing the sound source from main left and right speakers, splendid sound effect occurs, which enhance movement of sound.

- * Rear speakers: left and right

Add three-dimensional movement of sound and create full background sound effect.

- * Subwoofer

Create rich and strong bass effect.

Least Speaker Composite for Playing Surround Sound:

- * Main speakers: left and right
- * Rear speakers: left and right

The sound recorded for center speaker and subwoofer is properly distributed to main speakers and rear speakers to get the best surround sound effect.

Speaker Placement:

Perfect speaker placement is different according to the different room area and wall material. As the picture, it is the sample of speaker placement.

Notes about speaker placement:

Main speakers and center speaker:

Put the three speakers on the same height up from the ground.

When placing these speakers, sound should face the listener's ears in the listening position.

Rear speakers:

When placing the speakers, the position should be 1M higher than the listener's ears.

Subwoofer:

To get the best bass effect, you can place the subwoofer at any position of the room, because its position only has quite small effect on the sound.

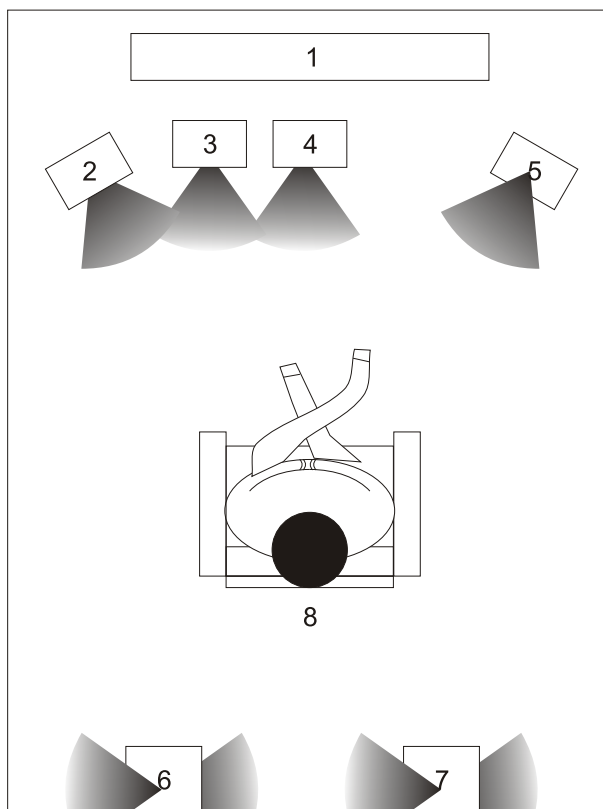

- 1 TV set or screen
- 2 Main left speaker
- 3 Subwoofer
- 4 Center speaker

- 5 Main right speaker
- 6 Surround left speaker
- 7 Surround right speaker
- 8 Listening position

SPEAKER CONNECTION

Speaker Connection:

Notes:

The speakers with impedance in a normal range will produce the best sound. Please confirm the following information, and select the speakers with proper impedance.

Caution:

- * Speaker impedance: the minimum impedance of every speaker terminal is 4Ohm.
- * To avoid circuit damage, do not let anode and cathode speaker cables occur short-circuit. (As the below picture)

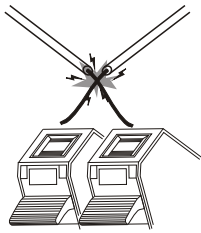

Speaker Cable Connection:

1. Cut out 15mm cable insulator
2. Tighten the cable terminal
3. Press the handle
4. Insert the cable terminal
5. Loose the handle

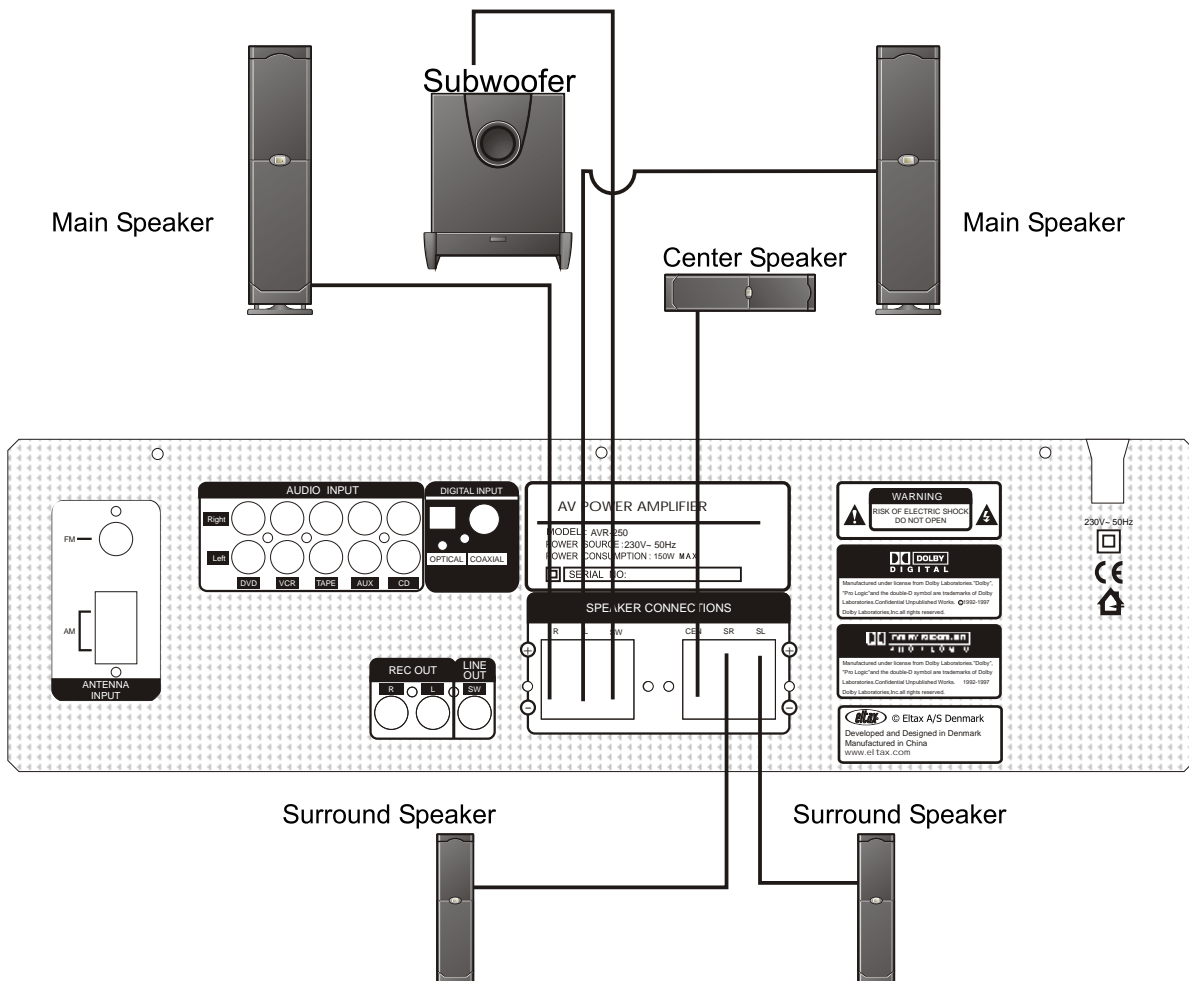
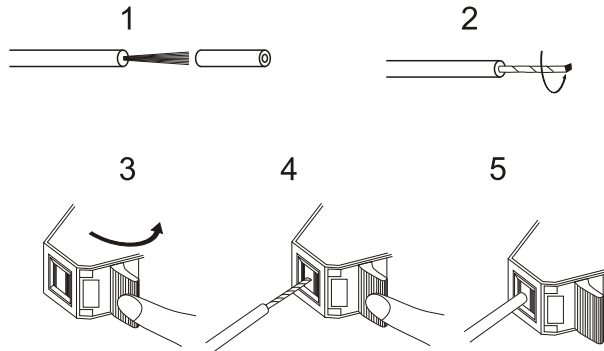

ANTENNA CONNECTION

Assemble AM loop antenna as below pictures

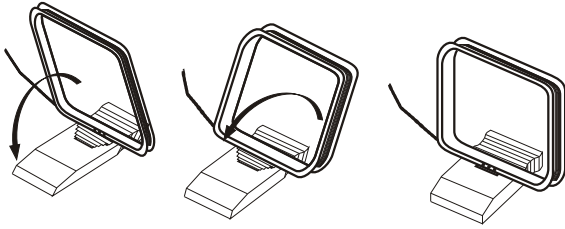

AM Antenna Connection

1. Press the handle
2. Put the cable into the hole
3. Loose the handle

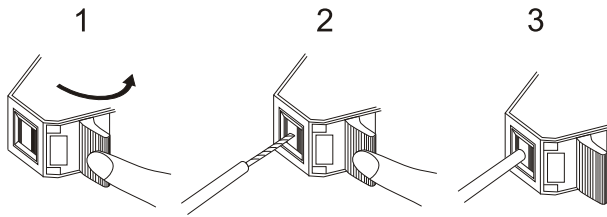

FM indoor antenna connection:

FM indoor antenna is only for indoor use. Pull the antenna, move to all directions till receiving the clearest signal, then fix it on the position with the smallest distortion.

If cannot receive clear sound with FM indoor antenna, please use the outdoor antenna.

AM Loop Antenna Connection

AM loop antenna is only for indoor use. Fix it on the position with the clearest receiving sound, and far away from the unit, TV set, speaker cables and power wires etc.

If cannot get satisfactory sound effect, please connect the outdoor antenna.

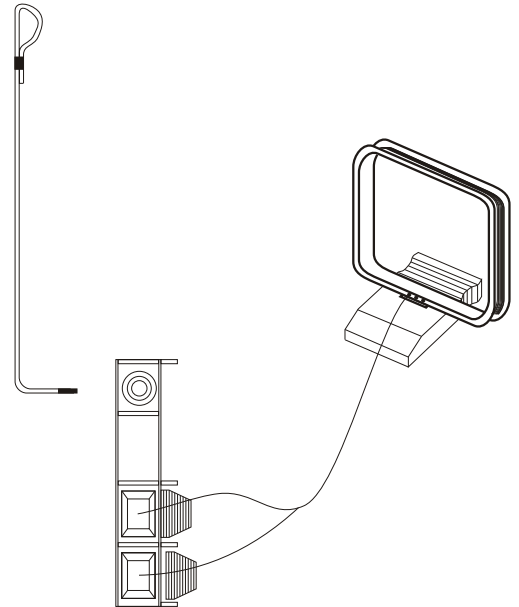

POWER CONNECTION

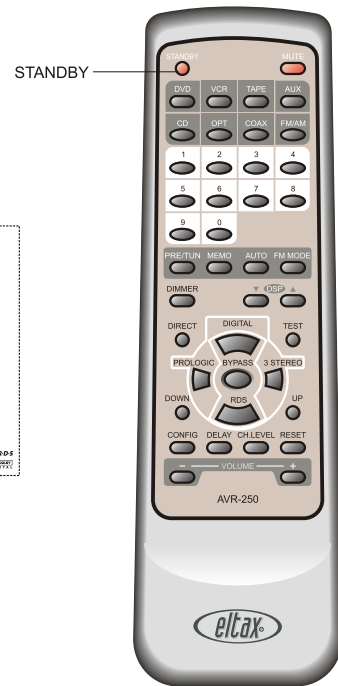
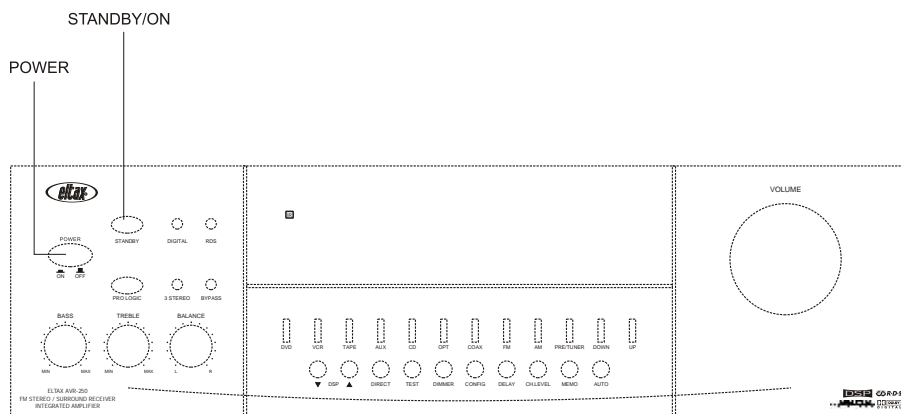

Power Connection

Be sure to all connections are completed before plug in this unit

When turn on the power, it may cause moment electrical surge and affect other electronic equipment(such as computer) in the same circuit. If so, please plug the unit in the wall outlet with the different circuit.

1. Connect the unit with the AC power wall outlet.
2. Press POWER and turn this unit on. If select the standby status, press STANDBY/ON.

Turn on the power by the remote commander

Do step 1 and 2 before using the remote commander.

Press STANBY/ON and exit the standby status.

If recover the standby status, press STANDBY/ON again.

SPEAKER SETUP

Speaker Configuration:

After connecting all components and confirming the speakers' place, you can configure the speakers to get the best sound effect.

The following parameter is very important before setup:

- * The speaker type and size
- * The distance between the speakers and the listening position
- * Speaker configuration

Set the speaker size as the following guide:

Large: The channel will play full range sound from the speaker.

Small: The unit will play sound lower than 80Hz from the subwoofer. If the main speakers are set to be "Large", the sound will play from the main L and main R speakers.

Operation:

Select the channel which should be adjusted by the CONFIG button, then change its value by the DOWN or UP button.

1. FRONT

Large: for large main speakers

Small: for small main speakers

If the subwoofer setup is "NO", the value will be fixed to "large".

2. CENT

None: for disconnecting center speaker

Large: for large center speaker

Small: for small center speaker

If the main setup is "Small", the value will not be set to "Large".

3. SURR

None: for disconnecting rear L and rear R speakers

Large: for large rear L/R speakers

Small: for small rear L/R speakers

If the main setup is "Small", the value will not be set to "Large".

4. SUBWF

Yes: for connecting subwoofer

No: for disconnection subwoofer

CHANNEL LEVEL SETUP

Adjust the volume of every speaker to make all volume from speakers same to the listener. The operation is special important to the left and right speakers in the different distance or the unequal position because of the room design and structure.

Select the channel by CH LEVEL, then adjust the setup by DOWN or UP. 1dB is a unit, the channel level is adjusted within the range of ± 10 dB.

* If the channel level is +1dB or higher, the maximum channel level on the VFD will change subject to its increase.

* If the speaker CONFIG is NONE, no sound input when testing noise.

BROADCASTING STATION PRESET

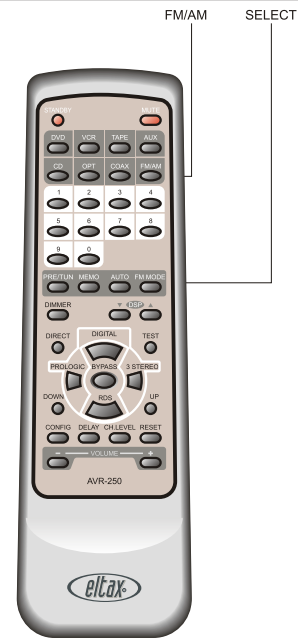
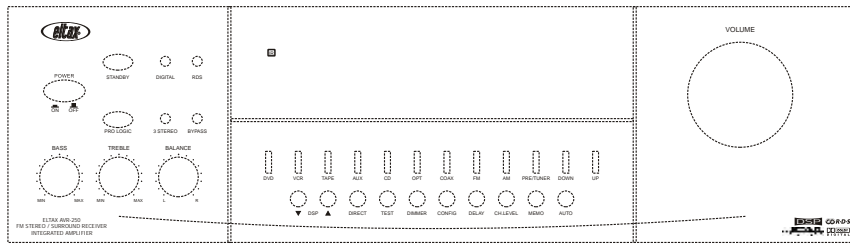

When Listening to FM/AM Radio

There is built-in high-sensitivity FM/AM receiver in this unit. It can broadcast FM/AM radio and its pre-setup function can make you easily select the station you often listen to.

When Tuning to Some Station

1. Press FM/AM, select wave band
 2. Press PRE/TUN button to get TUNING, select the frequency you need by DOWN/UP button
In FM, the tuner frequency will change per 50KHz; In AM, it will change per 9KHz.
- When tuning, if press DOWN/UP beyond a second of time, the system will enter the automatic search function. The tuner frequency will search a radio station and stop by the button's direction. Under tuning status, press AUTO and enter the full automatic search, the system will search from FM low frequency to high one and memory the radio stations with enough signal intensity.

Broadcasting Station Setup

1. Tune to the radio station frequency you need.
- RADIO STATION FREQUENCY
2. Press the MEMO button on the front panel, and VFD will display MEMORY.
 3. Select channel number from 1~30 by using DOWN/UP button.
 4. Press MEMO or wait for MEMORY disappearance, and complete the operation, which can set the radio station to be pre-set radio station, the maximum station number is 30.

When Selecting the preset station

1. Select FM or AM as input signal source
2. Press PRE/TUN button to get PRESET on the front panel, and select the channel number of the preset radiostation to the one you need by DOWN/UP button.

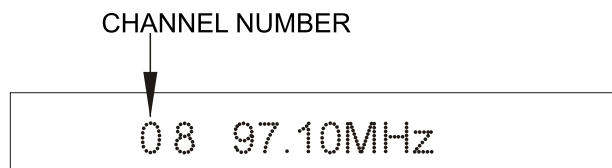

Basic function of RDS(radio data system)

1. Identify the broadcasting-station
2. Identify the program
3. Display the complex information
4. Time display

Operation:

RDS button can be applied while the signal with RDS received from broadcasting station and the station will be identified automatically. You can check the time, complex information, the program and frequency of the station by pressing RDS button. Once the RDS signal disappears the function should not be available.

SPECIFICATION

Amplifier:

Output power

AC-3 5.1 channel

5 x 60W

Subwoofer: 120W

Frequency response:

Main: 20Hz~20KHz \pm 3dB (AC-3 5.1)

Center: 20Hz~20KHz \pm 3dB (AC-3 5.1)

Surround: 20Hz~20KHz \pm 3dB (AC-3 5.1)

S/N: >80dB(A IHF)

Input sensitivity: 250mv, 47K Ohm

Channel separability : \approx 30dB

Normal specification:

Power source: AC 230V 50Hz

Maximum power consumption: 180W

Size:

Weight:

Remote commander:

Transmitter: infrared

Signal range: about 5M

Power source: 2 AAA 1.5V batteries

Tuner:

FM

Tuning range: 87.5~108.0MHz (50KHz interval)

50dB noise limited sensitivity:

Mono: 30dBu

Stereo: 40dbu

Mirror-frequency restriction ratio \geq 14dB

Mid-frequency restriction ratio \geq 65dB

S/N

Mono: >46dB

Stereo: >46dB

Selectivity: 50dB (DIN)

AM restriction ratio \geq 50dB

THD:

Mono: 2%

Stereo: 3%

Frequency response: 30Hz-10KHz, 6dB

AM

Tuning range: 522-1620KHz (9KHz interval)

26dB noise limited sensitivity: 70dBu

Mirror-frequency restriction ratio: 20dB

Mid-frequency restriction ratio: 40dB

S/N: 35dB

THD: 3%

The specification may be subject to change without notice.

TROUBLE SHOOTING

If the problem occurs when using the remote commander, you should operate this unit by the control buttons on the front panel, then confirm whether it caused by the trouble of the remote commander (or batteries use-up).

TROUBLE	SOLVING METHOD
No sound and all indicators are off	<ul style="list-style-type: none"> * Power is off or Power is not plugged * The "POWER" button is not pressed * The fuse does not work
No sound but indicator is on	<ul style="list-style-type: none"> * Minimum volume * Cable is not connected * The wrong signal cable are selected * No signal outputs
Main speaker no sound	<ul style="list-style-type: none"> * Incorrect cable connected
Only one side speaker outputs the sound	<ul style="list-style-type: none"> * Incorrect cable connected or short circuit * Signal source is mono or signal cut
No sound from the center channel	<ul style="list-style-type: none"> * Wrong channel mode set, reset 3 STEREO or PRO LOGIC * Wrong center switch mode, check whether CONFIG is NO * Cable is short circuit or cut
No sound from the surround speaker	<ul style="list-style-type: none"> * Wrong channel mode, reset to PRO LOGIC * cable is short circuit or cut
No surround effect	<ul style="list-style-type: none"> * The position for operation mode is wrong, reset PRO LOGIC * cable is short circuit or cut
This unit does not work normally & sound no good	<ul style="list-style-type: none"> * Cable is short circuit * Signal source is deviant * Voltage is over/high or low, normal voltage is 230V
All functions do not operated normally	<ul style="list-style-type: none"> * CPU in this device is protected, re-plug it

Note: If the problem still exists after solved by above methods, please contact the eligible maintaining person or local dealer. Never go your own way to repair it!