



AVR-800

6.1 Channel Home Theatre Receiver



OWNER'S MANUAL



CAUTION
RISK OF ELECTRICAL SHOCK
DO NOT OPEN



CAUTION: TO REDUCE THE RISK OF ELECTRICAL SHOCK, DO NOT REMOVE COVER (OR BACK). NO USER-SERVICEABLE PARTS INSIDE. REFER SERVICING TO QUALIFIED SERVICE



The lightning flash with arrowhead symbol, within an equilateral triangle, is intended to alert the user to the presence of uninsulated "dangerous voltage" within the product's enclosure that may be of sufficient magnitude to constitute a risk of electric shock to persons.



The exclamation point within an equilateral triangle is intended to alert the user to the presence of important operating and maintenance (servicing) instructions in the literature accompanying the appliance.

WARNING: TO PREVENT FIRE OR SHOCK HAZARD, DO NOT EXPOSE THIS APPLIANCE TO RAIN OR MOISTURE.

FOREWORD

This section must be read before any connection is made to the mains supply.

WARNINGS

Do not expose the equipment to rain or moisture.
Do not remove the cover from the equipment.
Do not push anything inside the equipment through the ventilation holes.
Do not handle the mains lead with wet hands.

EQUIPMENT MAINS WORKING SETTING

Your ELTAX product has been prepared to comply with the household power and safety requirements that exist in your area.
AVR-800 can be powered by 230 V AC only.

IMPORTANT:(FOR UK VERSION)

This apparatus is fitted with an approved moulded 13 Amp plug.

To change a fuse in this type of plug proceed as follows:

1. Remove fuse cover and fuse.
 2. Fix new fuse which should be a BS1362 13A, A.S.T.A or BSI approved type.
 3. Refit the fuse cover.
- If the fitted plug is not suitable for your socket outlets, it should be cut off and an appropriate plug fitted in its place.
If the mains plug contains a fuse, this should have a value of 13A.
If a plug without a fuse is used, the fuse at the distribution board should not be greater than 5A.

Note:

The severed plug must be destroyed to avoid a possible shock hazard should it be inserted into a 13A socket elsewhere.

HOW TO CONNECT A PLUG

The wires in the mains lead are coloured in accordance with the following code.

BLUE-"NEUTRAL"("N")

BROWN-"LIVE"("L")

1. The BLUE wire must be connected to the terminal which is marked with the letter "N" or coloured BLACK.
2. The BROWN wire must be connected to the terminal which is marked with the letter "L" or coloured, RED.
3. Do not connect either wires to the earth terminal in the plug which is marked by the letter "E" or by the safety earth symbol or coloured green-and-yellow.

Before replacing the plug cover, make certain that the cord grip is clamped over the sheath of the lead-not simply over the two wires.

COPYRIGHT

Recording and playback of any material may require consent. For further information refer to the following:

- Copyright Act 1956
- Dramatic and Musical Performers Act 1958
- Performers Protection Acts 1963 and 1972
- any subsequent statutory enactments and orders.

ABOUT THIS USER GUIDE

Refer to the figures on page 2 of this user guide. All references to the controls that are printed in BOLD type are as they appear on the unit.

PRECAUTIONS

The following precautions should be taken when operating the equipment.

GENERAL PRECAUTIONS

When siting the equipment ensure that:

- The ventilation holes are not covered;
 - Air is allowed to circulate freely around the equipment
 - It is on a vibration free-surface;
 - It will not be exposed to interference from an external source;
 - It will not be exposed to excessive heat, cold, moisture or dust;
 - It will not be exposed to direct sunlight;
 - It will not be exposed to electrostatic discharges
- Never place heavy objects on the equipment.
If a foreign body or water does enter the equipment, contact your nearest dealer or service centre.
Do not pull out the plug by pulling on the mains lead, hold the plug.
It is advisable when leaving the house, or during a thunderstorm, to disconnect the equipment from the mains supply.

The equipment draws nominal nonoperating power from the AC outlet with its POWER switch in the STANDBY position.

WARNING:
TO PREVENT FIRE OR SHOCK HAZARD, DO NOT EXPOSE THIS APPLIANCE TO RAIN OR MOISTURE.



This symbol means that the product is double insulated and you do not need an earth connection



This symbol means that this product keeps to the European safety and electrical interference directives

CAUTION Regarding Placement

To maintain proper ventilation, be sure to leave a space around the unit (from the largest outer dimensions including projections) equal to, or greater than, shown below :

- Left and right Panels : 10cm
- Rear Panel : 10cm
- Top Panel : 50cm

Before Use.....4

Description5

Connection6

Remote Control Unit.....12

Basic Operations.....13

Radio Reception15

RDS Operations17

Video Operations.....18

Playing Video Sources.....18

Tape Dubbing.....18

S.A.V.E System Function.....18

Available Surround Modes.....19

Speaker Configuration.....22

Delay Time.....23

Test Tone.....24

Troubleshooting.....25

Specifications.....26

INTRODUCTION

This instruction manual is important to you. Please read it. In a short time it shows exactly how to connect, operate and adjust this unit for best performance.

It can save you money. It shows simple things to do and check before you call for help and can save the cost of unnecessary service or call out charge.

WARNING: TO REDUCE THE RISK OF FIRE OR ELECTRIC SHOCK, DO NOT EXPOSE THIS APPLIANCE TO RAIN OR MOISTURE. DANGEROUS HIGH VOLTAGES ARE PRESENT INSIDE THE ENCLOSURE. DO NOT OPEN THE CABINET. REFER SERVICING TO QUALIFIED PERSONNEL ONLY.

Read this before operation

Read this before operation

- < Choose the installation location of your unit carefully. Avoid placing it in direct sunlight or close to a source of heat. Also avoid locations subject to vibrations and excessive dust, heat, cold or moisture.
- < The ventilation holes should not be covered. Make sure there is enough space above and beside the amplifier/receiver (about 4 inches). Do not place a CD player or other equipment on top of the amplifier/receiver.
- < Do not open the cabinet as this might result in damage to the circuitry or electrical shock. If a foreign object should get into the set, contact your dealer.
- < When removing the power plug from the wall outlet, always pull directly on the plug, never yank the cord.
- < Do not attempt to clean the unit with chemical solvents as this might damage the finish. Use a clean, dry cloth.
- < Keep this manual in a safe place for future reference.

Back-up Memory Function

This is the function which preserves the preset memory and most-recent memory functions. In the event of a power failure, or if the power cord of this unit is disconnected from the electric outlet, the back-up memory will preserve the preset memory and most-recent memory functions for as long as approximately 3 days.

If the power supply is interrupted for 3 days or longer, the memory settings will be erased.

When to Use RESET Switch

- < When this system is subjected to an electrical shock.
 - < When the power is irregular.
- In these cases, try the following

Press the TUNING MODE button for more than 5 seconds.

Note:

If the TUNING MODE button is pressed for more than 5 seconds Standby mode, all the memory will be erased.

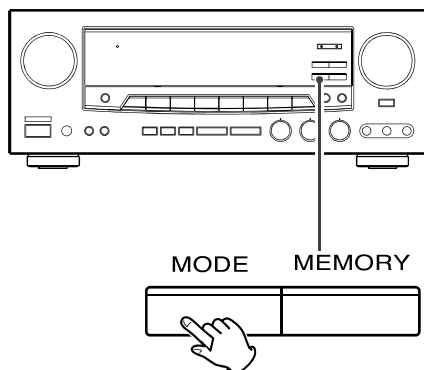

Before Connection

CAUTION

Turn off the power of all the equipment before making connections. Read instructions of each component you intend to use with this unit.

- < Be sure to insert each plug securely. To prevent hum and noise, do not bundle the connection cords with the power cord or speaker cord.

Speaker Connections

Caution:

To avoid damaging the speakers with a sudden high-level signal, be sure to switch the power off before connecting the speakers.

- < Check the impedance of your speakers. Connect speaker with an impedance of 8 ohms or more. The amplifier's red speaker terminals are the + (positive) terminals and the black terminals are the - (negative) terminals.
- < The + side of the speaker cable is marked to make it distinguishable from the - side of the cable. Connect this marked side to the red+ terminal and the unmarked side to the black terminal.
- < Prepare the speaker cords for connection by stripping off approximately 10 mm or less (no more as this could cause a short-circuit) of the outer insulation. Twist the wires tightly together so that they are not straggly :

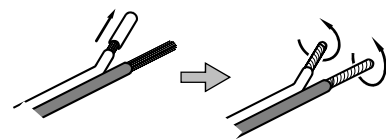

How to connect

Press the lever, insert the stripped and twisted end (approx. 3/8") of the cord, then release the lever : Make sure it is fastened securely by pulling the cord lightly.

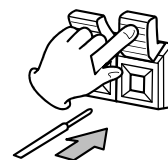



DTS was introduced in 1994 to provide 5.1 channels of discrete digital audio into home theater systems. DTS brings you premium quality discrete multi-channel digital sound to both movies and music. DTS is a multi-channel sound system designed to create full range digital sound reproduction. The no compromise DTS digital process sets the standard of quality for cinema sound by delivering an exact copy of the studio master recordings to neighborhood and home theaters. Now, every moviegoer can hear the sound exactly as the moviemaker intended. DTS can be enjoyed in the home for either movies or music on DVD's, LD's, and CD's.

"DTS" and "DTS Digital Surround" are registered trademarks of Digital Theater Systems, Inc.



The advantages of discrete multichannel systems over matrix are well known. But even in homes equipped for discrete multichannel, there remains a need for high-quality matrix decoding. This is because of the large library of matrix surround motion pictures available on disc and on VHS tape; and analog television broadcasts. The typical matrix decoder of today derives a center channel and a mono surround channel from two-channel matrix stereo material. It is better than a simple matrix in that it includes steering logic to improve separation, but because of its mono, band-limited surround it can be disappointing to users accustomed to discrete multichannel.

Neo6 offers several important improvements as follow.

- < Neo 6 provides up to six full-band channels of matrix decoding from stereo matrix material. Users with 6.1 and 5.1 systems will derive six and five separate channels, respectively. corresponding to the standard home-theater speaker layouts.
- < Neo 6 technology allows various sound elements within a channel or channels to be steered separately, and in a way which follows naturally from the original presentation.
- < Neo 6 offers a music mode to expand stereo nonmatrix recordings into the five-or six-channel layout, in a way which does not diminish the subtlety and integrity of the original stereo recording.



DTS-ES Extended Surround is a new multi-channel digital signal format developed by Digital Theater Systems Inc. While offering high compatibility with the conventional DTS Digital Surround format, DTS-ES Extended Surround greatly improves the 360-degree surround impression and space expression thanks to further expanded surround signals. This format has been used professionally in movie theaters since 1999.

In addition to the 5.1 surround channels (FL, FR, C, SL, SR and LFE), DTS-ES Extended Surround also offers the SB (Surround Back) channel for surround playback with a total of 6.1 channels. DTS-ES Extended Surround includes two signal formats with different surround signal recording methods, as DTS-ES Discrete 6.1 and DTS-ES Matrix 6.1.

"DTS", "DTS-ES Extended Surround" and "Neo:6" are trademarks of Digital Theater Systems, Inc.



Dolby Digital identifies the use of Dolby Digital (AC-3) audio coding for such consumer formats as DVD and DTV. As with film sound, Dolby Digital can provide up to five full-range channels for left, center, and right screen channels, independent left and right surround channels, and a sixth (".1") channel for low-frequency effects.

Dolby Surround Pro Logic II is an improved matrix decoding technology that provides better spatiality and directionality on Dolby Surround program material; provides a convincing three-dimensional soundfield on conventional stereo music recordings; and is ideally suited to bring the surround experience to automotive sound. While conventional surround programming is fully compatible with Dolby Surround Pro Logic II decoders, soundtracks will be able to be encoded specifically to take full advantage of Pro-Logic II playback, including separate left and right surround channels. (Such material is also compatible with conventional Pro Logic decoders.)

Dolby Digital EX creates six full-bandwidth output channels from 5.1-channel sources. This is done using a matrix decoder that derives three surround channels from the two in the original recording. For best results, Dolby Digital EX should be used with movies soundtracks recorded with Dolby Digital Surround EX.

Manufactured under license from Dolby Laboratories. "Dolby", "ProLogic", and the double-D symbol are trademarks of Dolby Laboratories.

SPEAKERS, PRE OUT, AC OUTLETS

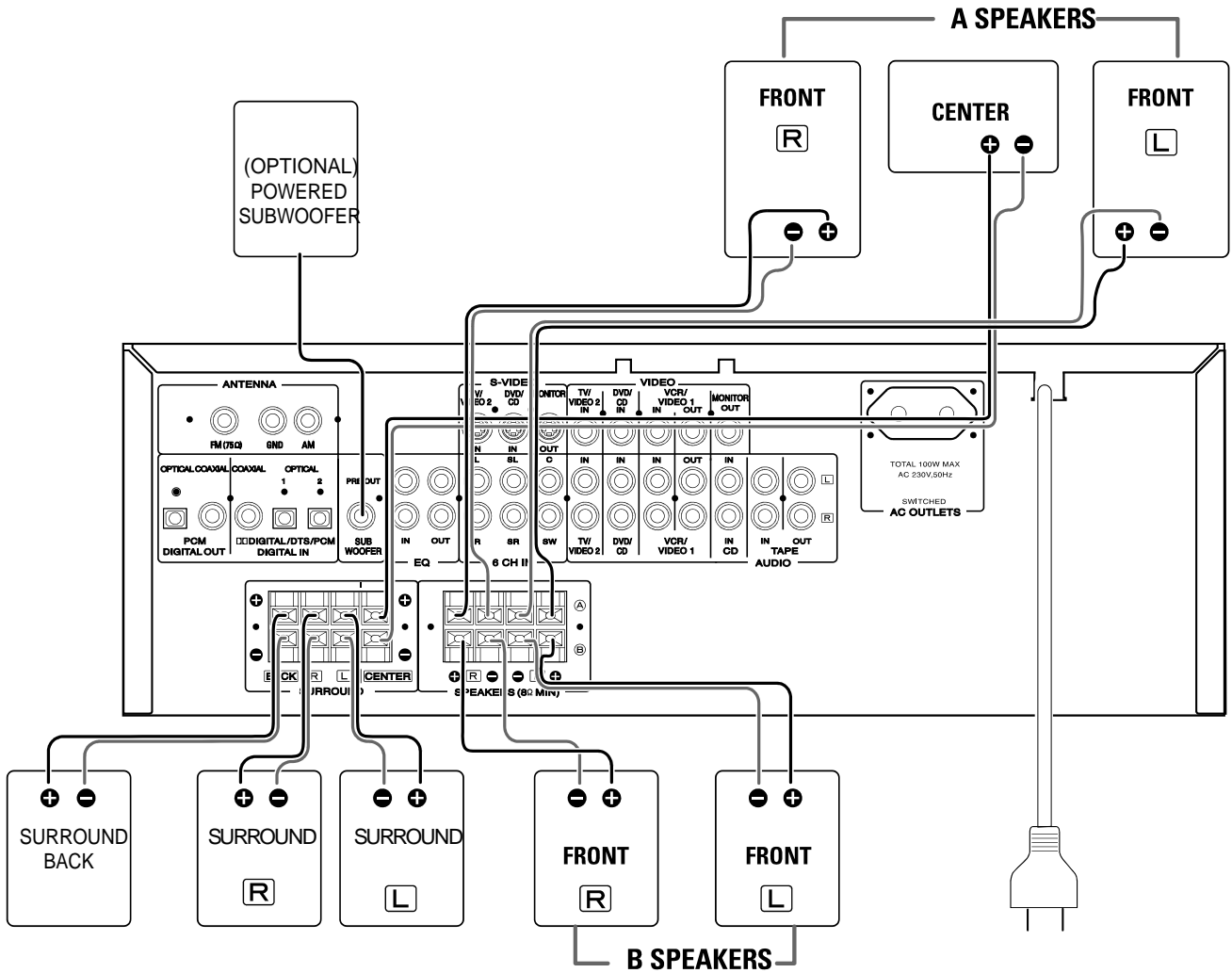

Power cord (AC)

Be sure to connect the power cord to an AC outlet which supplies the correct voltage.

Hold the power plug when plugging or unplugging the power cord.

PRE OUT (SUB WOOFER) jack

Use this jack to connect a powered sub-woofer or passive sub-woofer with a power amplifier (OPTIONAL) .

AC OUTLETS (SWITCHED)

These outlets are only active when the receiver is turned on.

Caution:

Make sure that the total power consumption of all equipment connected to the outlets on the receiver does not exceed 100 watts.

6 CHANNEL INPUT FOR DVD AUDIO, EQ

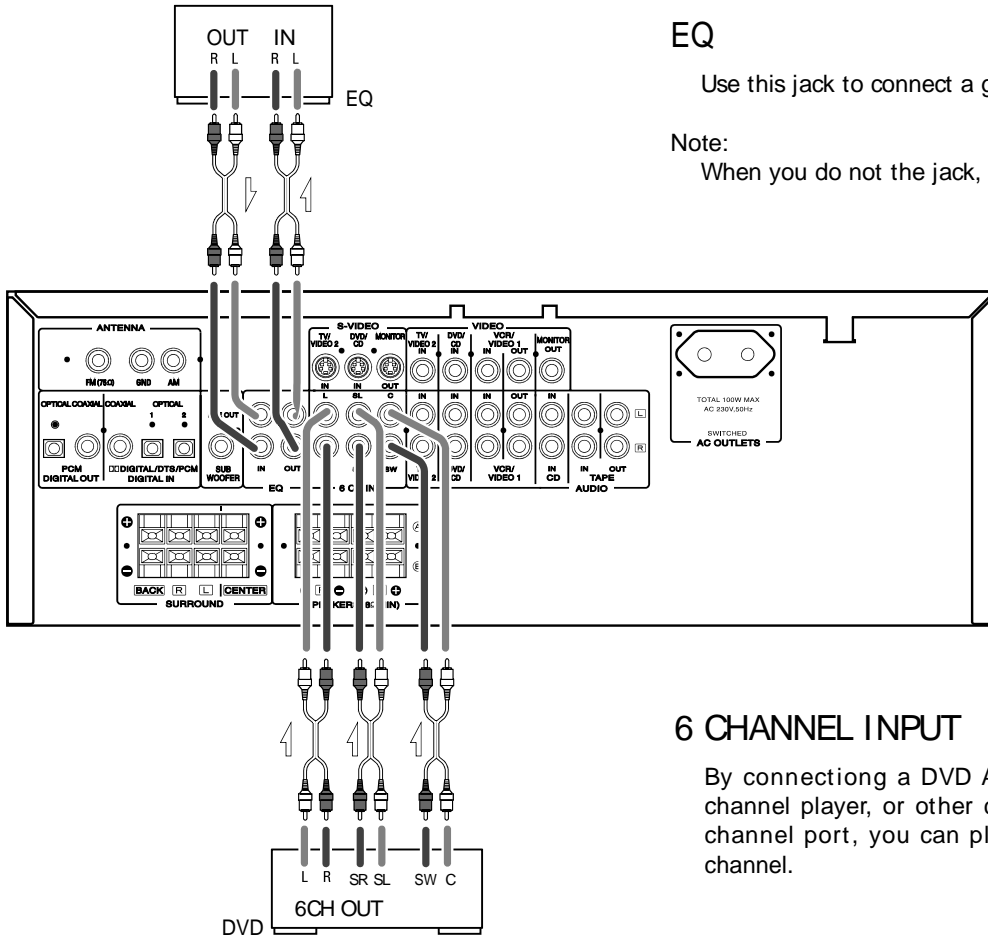

EQ

Use this jack to connect a graphic equalizer.

Note:

When you do not use the jack, You must insert "short pin".

6 CHANNEL INPUT

By connecting a DVD Audio player, SACD multi channel player, or other component that has a multi channel port, you can playback the audio with 5.1 channel.

VCR

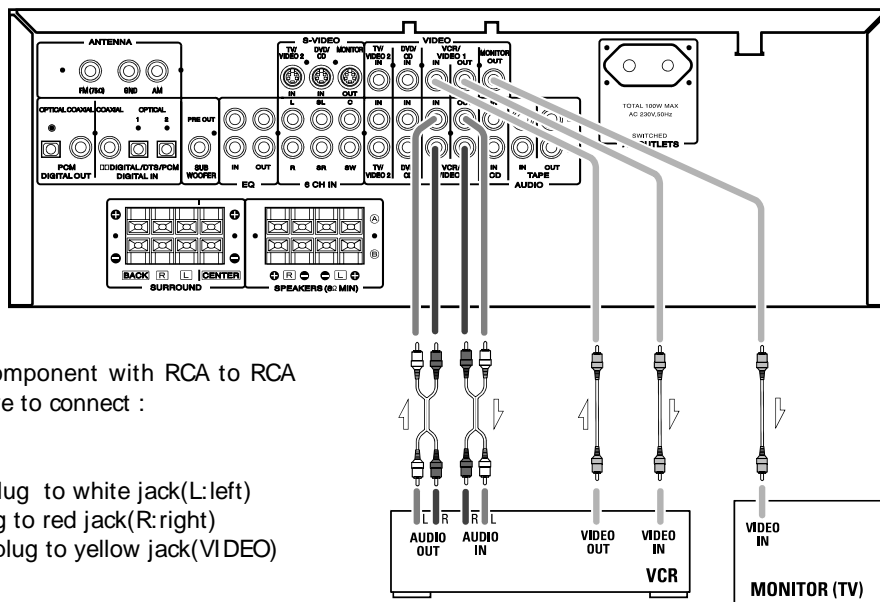

Connect the component with RCA to RCA cords. Make sure to connect :

- white plug to white jack(L:left)
- red plug to red jack(R:right)
- yellow plug to yellow jack(VIDEO)

DVD PLAYER, CABLE BOX, SATELLITE RECEIVER (DSS), TELEVISION (MONITOR)

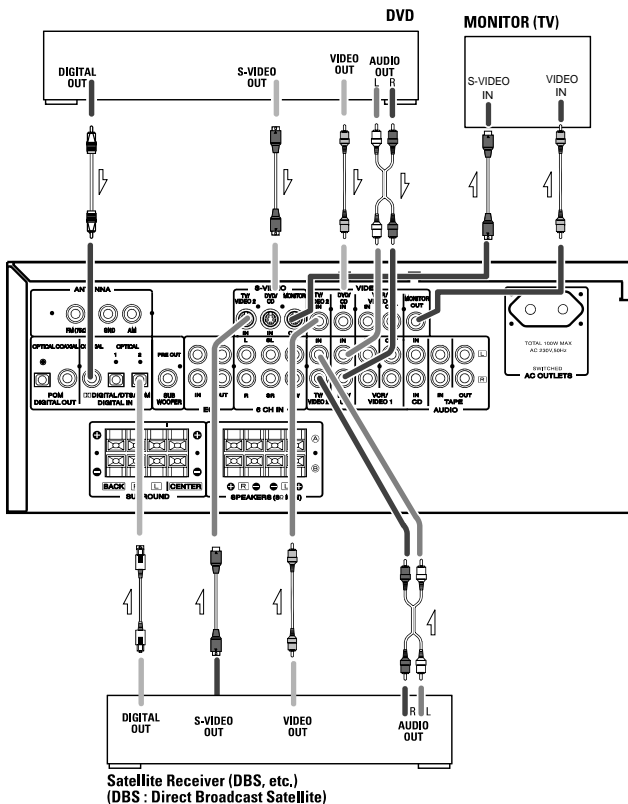

Satellite Receiver (DBS, etc.)
(DBS : Direct Broadcast Satellite)

When connecting video components such as DVD players, cable boxes, satellite receivers and televisions, you can use different types of cables depending on how the video component is equipped.

Video connections:

If the video component is equipped with S-VIDEO jacks, it is recommended that it be connected to the AVR-800 or directly to the television monitor using an S-VIDEO cable. S-Video cables provide better picture clarity and resolution. If the video component is not equipped with an S-VIDEO jack, use a conventional RCA to RCA composite cable to connect to the AVR-800 or directly to the television.

The above illustration shows how to connect video components to the AVR-800.

Note:

When connection more than one video component to the AVR-800 (ie: VCR and DVD player) it is easier to use either all S-Video cables or all RCA to RCA composite cables. This allows both video signals (DVD and VCR) to be sent through the AVR-800 to the TV monitor using just one video input on the TV (S-Video or RCA). Regardless of the video component being played DVD or VCR, the picture will always appear on the same video input of the monitor.

If you use both S-Video and RCA composite cables to connect different video components to the AVR-800, you must also use both S-Video and RCA composite cables to connect the TV monitor to the AVR-800.

For example, if you connect a DVD player to the AVR-800 using S-Video cable and a VCR using an RCA to RCA composite cable, you must also connect the TV to the AVR-800 using both types of cables. This requires an S-Video cable from the S-Video monitor out jack on the AVR-800 to an S-Video input on the TV (ie. Video 1). In addition, you must use an RCA composite cable from the composite video monitor out jack on the AVR-800 to an RCA composite video input on the TV but not the same input used for the S-Video cable (ie: Video 2). Using this type of dual cable video connection, you will need to switch the TV video input source from TV to Video 1 to Video 2 depending on the video source being played-TV, DVD or VCR.

Audio connections:

Some video components are equipped with special digital audio outputs (ie: DVD players). If your video component is equipped with a digital audio output, it is recommended that you connect to the AVR-800 using a digital cable. Digital audio cables are required to use the DTS and Dolby Digital surround sound modes. If you do not use digital connections, the AVR-800 will only operate in Dolby Pro LogicII, Dolby 3 Stereo, Hall, Theater and Stadium surround modes.

There are two types of digital cables - coaxial (75 ohm) and optical. The AVR-800 is equipped with both types of digital inputs. These inputs are labeled DIGITAL/DTS/PCM on the rear of the unit. Connect the video component outputs to any one of the three digital inputs on the AVR-800.

If the video component is not equipped with a digital output, use a dual RCA to RCA composite audio cable to connect to the AVR-800.

Make sure to connect:

- White plug to white jack (L : left)
- Red plug to red jack (R : right)

Note:

When an optical cable is used, remove the protection caps from the component and AVR-800 before attempting to insert the optical cable. If not using an optical cable or if the cable is removed, always re-install the protection caps to prevent dirt and dust from entering the inputs. If using a coaxial digital cable, leave the protection caps in both the video component and AVR-800.

CD, TAPE Jacks

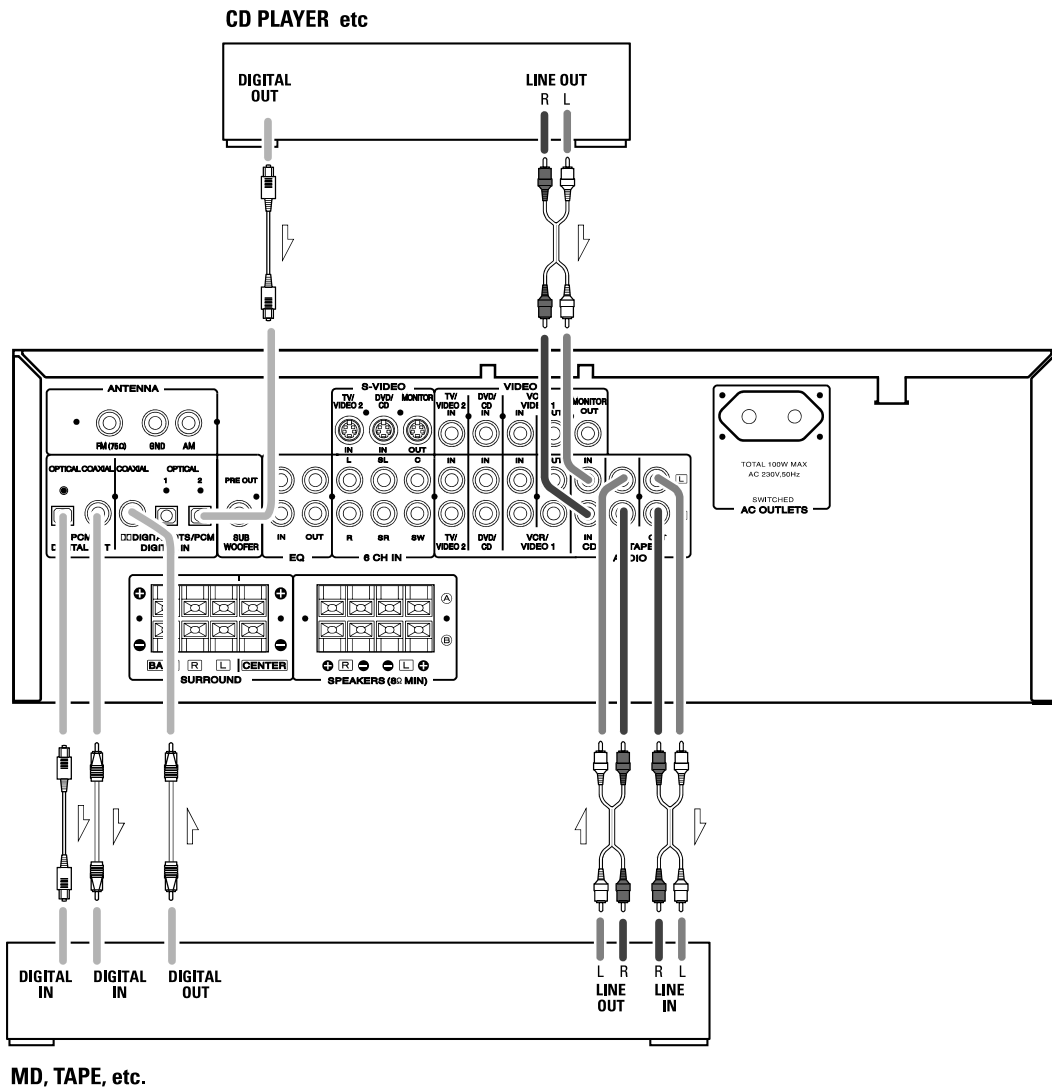

CD, TAPE jacks

Connect the component with RCA to RCA cords. Make sure to connect :

- white plug to white jack(L:left)
- red plug to red jack(R:right)

DIGITAL IN/OUT terminals

If the CD player or tape player has digital outputs, connect the component with coaxial cables or optical cables.

- DIGITAL IN to DIGITAL OUT(CD, etc.)
- DIGITAL OUT to DIGITAL IN(MD, etc.)

- < Connect to any one of the DIGITAL IN terminals.
- < When using DIGITAL OPTICAL IN terminals, remove the caps from the terminals. When you do not use them, leave the caps in place.
- < To record digitally, connect the source(CD player, etc.) to DIGITAL IN and the recorder(MD, etc.) to DIGITAL OUT.

Speaker layout example when using SURROUND MODE or 3 STEREO

SURROUND

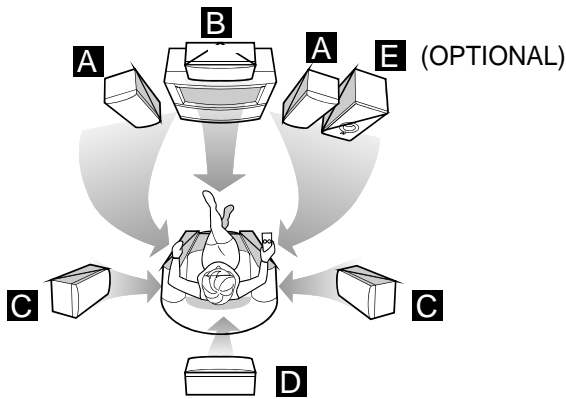

3 STEREO

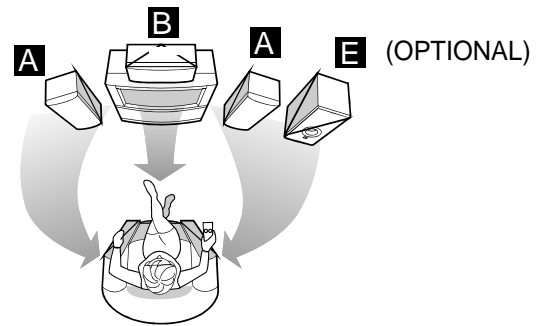

Positioning of the Speakers

The positioning of speakers differs according to the size and acoustics of the listening room. While actually listening to a program source, try various speaker positions to determine which layout provides the best surround effect.

Place the speakers connected to "L" to your left, and "R" to your right.

A Front speakers

Use magnetic shielded speakers, if you are using it near your TV.

Place the front speakers in front of the listening position, to the left and right of a TV.

Front speakers are required for all surround modes.

B Center speaker

Use magnetic shielded speaker, if you are using it near your TV.

Place a center speaker between the front speakers, on or below the TV.

This speaker improves sonic imaging and depth of field. Be sure to connect a center speaker when using the 3 STEREO mode.

C Surround speakers

Install these speakers above the level of the listener's ears, to the left and right.

Do not install the Surround speakers too far behind the listening position. It might be effective to direct the Surround speakers towards a wall or ceiling to further disperse the sound.

D SURR. BACK SPEAKER

Set the distance from a surround back speaker to your normal listening position between 1 and 30 feet in 1.0-foot Intervals (0.3 to 9 meters In 0.3-meter Intervals). Place the speaker behind of the listening position.

E Subwoofer (Optional)

Reproduces powerful and deep bass sounds.

Use a subwoofer with built-in amplifier.

A Subwoofer is not required but may be added as an option.

Remote sensor

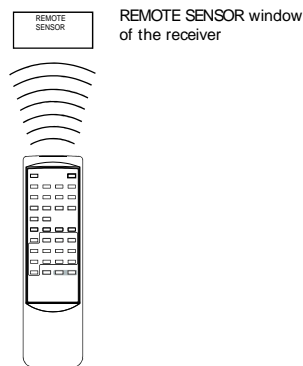

By using the provided remote control unit, the receiver can be controlled from your listening position.

To use the remote control unit, point it at the REMOTE SENSOR window of the receiver.

Notes:

- < Even if the remote control unit is operated within the effective range, remote control operation may be impossible if there are any obstacles between the unit and the remote control.
- < If the remote control unit is operated near other appliances which generate infrared rays, or if other remote control devices using infrared rays are used near the unit, it may operate incorrectly.

Precautions concerning batteries

- < Be sure to insert the batteries with correct positive "+" and negative "-" polarities.
- < Use batteries of the same type. Never use different types of batteries together.
- < Rechargeable and non-rechargeable batteries can be used. Refer to the precautions on their labels.
- < When the remote control unit is not to be used for a long time (more than a month), remove the batteries from the remote control unit to prevent them from leaking. If they leak, wipe away the liquid inside the battery compartment and replace the batteries with new ones.
- < Do not heat or disassemble batteries and never dispose of old batteries by throwing them in a fire.

Battery Installation

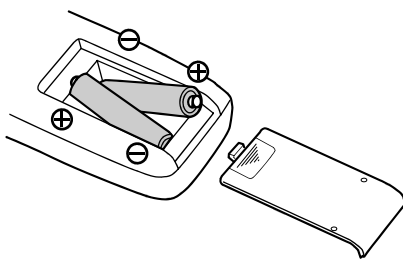

- 1** Remove the battery compartment cover.
 - 2** Insert two "AA(UM-3, R6)" dry batteries.
Make sure that the batteries are inserted with their positive "+" and negative "-" poles positioned correctly.
 - 3** Close the cover until it clicks.
- < If the distance required between the remote control unit and main unit decreases, the batteries are exhausted. In this case replace the batteries with new ones.

Basic Operations (1)

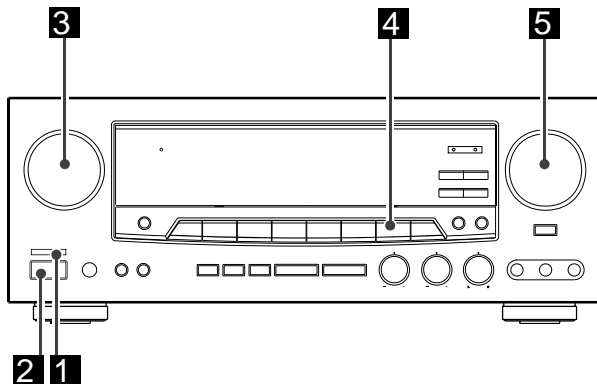

- 1** Press the POWER button to ON.
- 2** Press the STANDBY/ON button to ON.
- 3** Select the desired source with the FUNCTION (source) selector.
 - VCR/VID 1
 - TV/ VID 2 (OPT 1, OPT 2, COAX)
 - AUX/ VID 3 (OPT 1, OPT 2, COAX)
 - DVD/ CD (OPT 1, OPT 2, COAX)
 - TAPE
 - CD/ (OPT 1, OPT 2, COAX)
 - TUNER (frequency)
 - 6CH IN

4 When TV, DVD, AUX or CD is selected, press the DIGITAL INPUT button and select "OPTICAL-1", "OPTICAL-2", "COAXIAL" or "ANALOG" in accordance with your connection.

If "DIGITAL" blinks on the display:
 A digital input source (OPT 1, 2, COAX) has been selected, but the source isn't connected or is not switched on.
 In that case, connect and switch the source on, or select ANALOG by pressing the DIGITAL INPUT button.

- 5** Play the source, and gradually turn up the volume to the required level with the MASTER VOLUME control.

Recording a Source

You can record a source such as a Compact Disc onto a cassette tape connected to the TAPE REC jacks.

- 1** Turn the FUNCTION (source) selector corresponding to the source to be recorded.
- 2** Start recording.

Basic Operations (2)

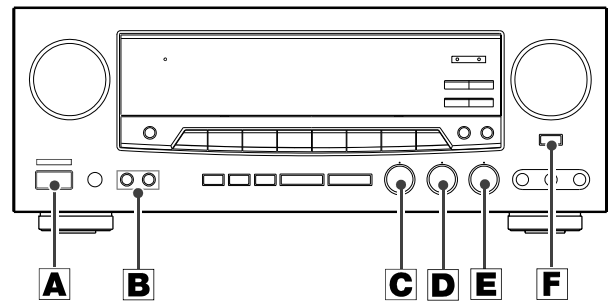

- A** STANDBY/ON Button
 When the POWER button is "ON", Press this button to turn the power on.
 Press it again to turn the system off (power standby mode).
 The STANDBY indicator lights up in power standby mode and goes out when this unit is turned on.
- B** SPEAKER Select Button
 With the unit in the STEREO mode or the SURROUND MODEs (DTS, DOLBY DIGITAL, DOLBY PRO LOGIC II, 3 STEREO, other SURROUND MODEs) SPEAKERS A and B can be selected simultaneously.

Notes:
 When the speaker A and B is selected simultaneously, You must connect certainly speaker both A and B.
 Otherwise speaker is not operate.

- C** Bass Control
 This control is used for adjusting the level of the low frequency sound range.
- D** Treble Control
 This control is used for adjusting the level of the high frequency sound range.
- E** BALANCE Control
 This control is used to adjust the balance of the front speakers.
 Normally set to the center position.
- F** BASS BOOST Switch
 Bass frequencies (lows) can be increased by pressing the bass boost switch. However, do not use the bass boost feature at high volume levels or permanent damage may occur to your speakers.

Basic Operations (3)

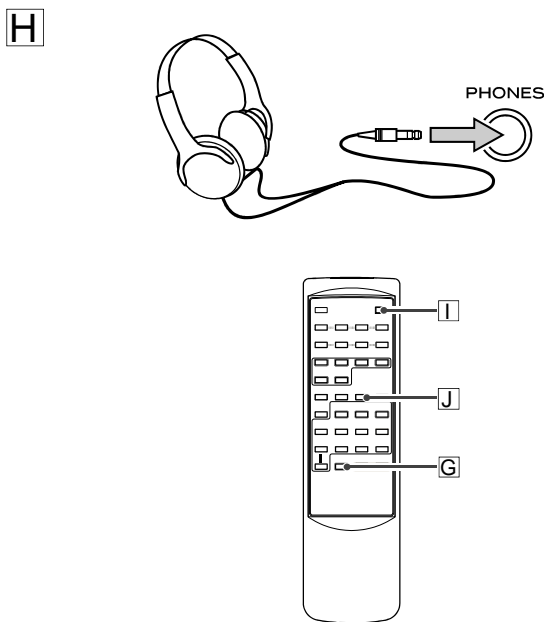
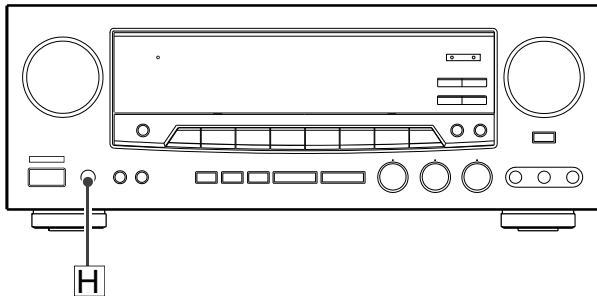

G Muting

To mute the sound temporarily, press the MUTING button. Press the MUTING button again to restore the sound. If you change the volume during the muting, the muting will be canceled.

While muting is engaged, the MUTING indicator will flicker.

H PHONES jack

For private listening, insert optional (not included) headphones (1/4-inch plug) into the PHONES jack, and press the SPEAKER ON/OFF button to cut the sound from speakers.

Note:

Change the Surround mode to STEREO when using the headphones.

I Sleep Timer Function

This function allows you to preprogram the receiver to switch its own power off automatically. You can then enjoy the audio/video system for a specified amount of time without having to worry about turning the unit off later. Each press of the SLEEP button changes the time indication by 10 minutes.

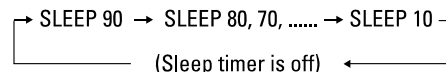

To let the remaining time (until power off) appear on the display while the sleep timer is engaged, press the SLEEP button once.

J NIGHT MODE function

When very dynamic movie soundtracks are played at low volume, such as late at night, you can use Night Mode to apply appropriate compression so that low-level program content is not lost and high level effects are restrained. (DOLBY DIGITAL only)

Radio Reception (1)

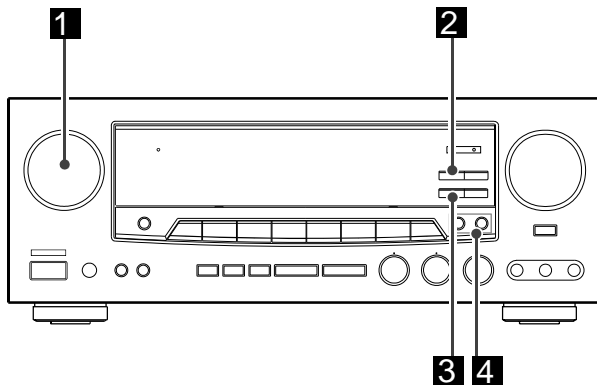

1 Select the TUNER mode by turning the FUNCTION selector.

2 Select the AM or FM by pressing the BAND button.

3 Press the MODE (TUNING) button to change to TUNING mode.

The "PRESET" indicator disappears from the display.

< This button is used to select Tuning or Preset scan mode.

4 Select the station you want to listen to (auto selection).

Hold down the TUNING button for 0.5 to 2 seconds.

When a station is tuned in, the tuning process will stop automatically.

Press the TUNING button to stop the auto selection.

< Selecting stations which cannot be tuned automatically (manual selection)

Press the TUNING button repeatedly or hold it down and release it when the station you want to listen to is found.

When the TUNING button is pressed momentarily (0.5 second or less), the frequency changes by a fixed step.

FM: 50 kHz steps

AM: 9 kHz steps

< "STEREO" is displayed when a stereo broadcast is tuned in.

< "TUNED" is displayed when a broadcast is correctly tuned in.

Radio Reception (2)

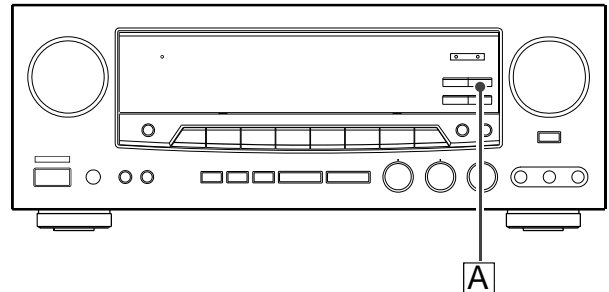

A FM MODE Button

Pressing this button alternates between Stereo mode and Mono mode.

Stereo

FM stereo broadcasts are received in stereo and the STEREO indicator lights in the display. If FM broadcasts with weak signal strength are received, the FM muting function works automatically to cut the signals, eliminating loud noise.

Mono

To compensate for weak FM stereo reception, select this mode. Reception will now be forced monaural, reducing unwanted noise.

Radio Reception (3)

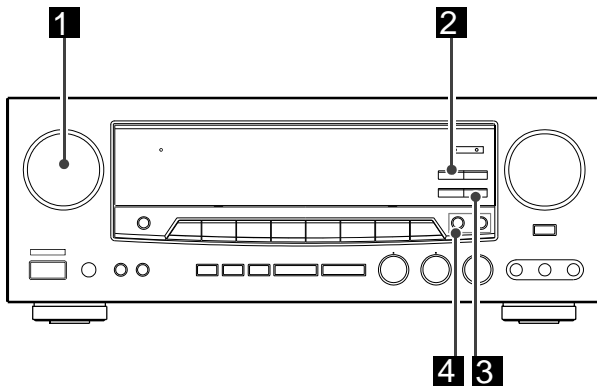

Preset Tuning

This facility is used to store FM, AM broadcasting from Channel 1 to 30 respectively.

Automatic Memory Prestting

- 1** Select the TUNER mode by turning the FUNCTION selector.
- 2** Select the AM or FM by pressing the BAND selector button.
- 3** Press the MEMORY button for more than 1.5 second.
Up to 30 of the best received stations in your area will be automatically stored.
- 4** Press the TUNING/PRESET button to change to preset channel.

Manual Memory Presetting

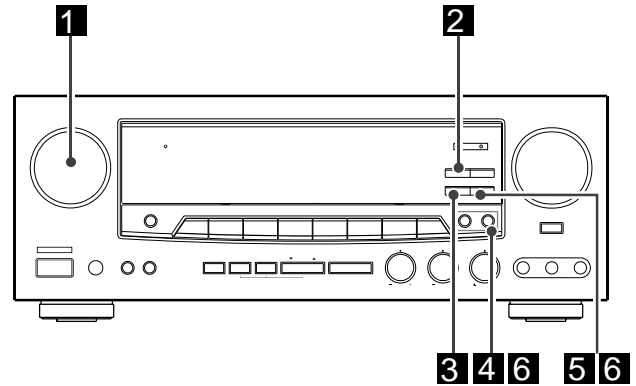

- 1** Select the TUNER mode by turning the FUNCTION selector.
- 2** Select the AM or FM by pressing the BAND selector button.
- 3** Press the MODE(TUNING) button to change the tuning mode from preset to manual.
The PRESET indicator disappears from the display.
- 4** Select the frequency you want to preset by pressing the PRESET button.
- 5** Press the MEMORY button briefly.
- 6** While the " — —" indicator is lit, select a preset channel to store the station using the PRESET buttons, and then press the MEMORY button.

To store more stations, repeat steps **4** to **6** .

RDS Operation

Now in use in many countries, RDS (Radio Data System) is a description of the station's programming hidden space in the FM signal.

Your new receiver is equipped with RDS to assist in the selection of FM stations using station and network names, rather than broadcast frequencies. Additional RDS functions include the ability to search for programme types.

RADIO TEXT

Some RDS stations broadcast RADIO TEXT, which is additional information on the station and programme being broadcast. RADIO TEXT information appears as 'running' text in the display. RADIO TEXT is transmitted character-by-character by the radio station. As a result of that it may take some time until the entire text has been completely received.

RDS DISPLAY

When a receiver is tuned to an FM station that is transmitting RDS data, the Front Panel Information Display will automatically show the station name or RDS TEXT in place of the typical display of the station's broadcast frequency.

To change the display, press the RDS button on the remote control unit.

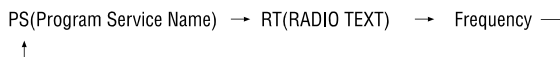

PROGRAMME TYPE(PTY) DISPLAY

The RDS system categorizes programmes according to their genre into different programme type(PTY)groups. To display the programme type information of the current station, press the PTY button in the TUNER MODE on the remote control unit.

PTY AUTO SEARCH

Your receiver is equipped to automatically search for stations transmitting any of 29 different programme types. To search for a PTY, follow these procedures.

1. Press the PTY button in the TUNER MODE on the remote controller, The current station's PTY will be displayed, or the currently selected PTY group will be displayed in blinking if no station or RDS data is present.
2. To change to a new PTY type, press the PRESET CALL(▲ or ▼) button until the desired PTY is shown in the display.

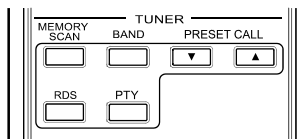

3. Once the desired PTY group or type has been selected, press the PTY button while the display blink (approx. 5 seconds). The PTY Auto search will start and the tuner will pause at each station broadcasting RDS PTY information corresponding to the selected choice.

4. To advance to the next RDS station with the desired PTY, press the PTY button again within 5 seconds.

NUMBER	DISPLAY	PROGRAMME TYPE
1	NEWS	News
2	AFFAIRS	Current Affairs
3	INFO	Information
4	SPORT	Sport
5	EDUCATE	Education
6	DRAMA	Drama
7	CULTURE	Culture
8	SCIENCE	Science
9	VARI ED	Varied
10	POP M	Pop Music
11	ROCK M	Rock Music
12	EASY M	Easy Listening Music
13	LIGHT M	Light classical
14	CLASSICS	Serious classical
15	OTHER M	Other Music
16	WEATHER	Weather
17	FINANCE	Finance
18	CHILDREN	Children's programmes
19	SOCIAL	Social Affairs
20	RELIGION	Religion
21	PHONE IN	Phone In
22	TRAVEL	Travel
23	LEI SURE	Leisure
24	JAZZ	Jazz Music
25	COUNTRY	Country Music
26	NATION M	National Music
27	OLDIES	Oldies Music
28	FOLK M	Folk Music
29	DOCUMENT	Documentary
30	TEST	Alarm test
31	ALARM	Alarm

Playing Video Sources

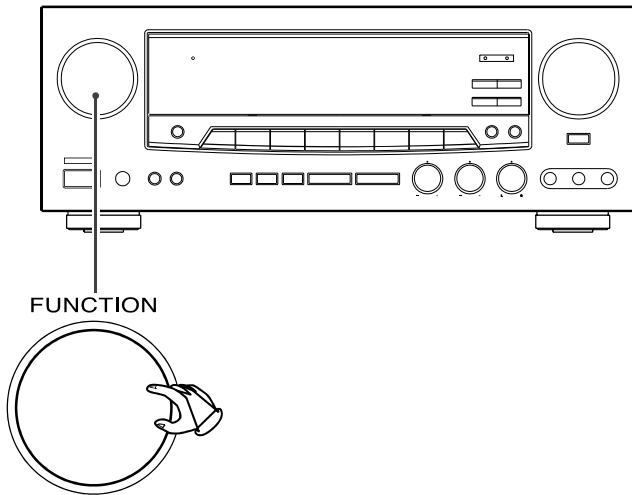

Note:

When playing videos that feature surround sound, refer to "Available Surround Modes".

- 1** Select the VCR/VID 1, TV/VID 2, AUX/VID 3 or DVD/CD mode by turning the FUNCTION selector.
- 2** Play the component corresponding to the FUNCTION selected.
- 3** The picture from the video source can be seen on the TV and the sound from the video source will be heard from the speakers.

Tape dubbing

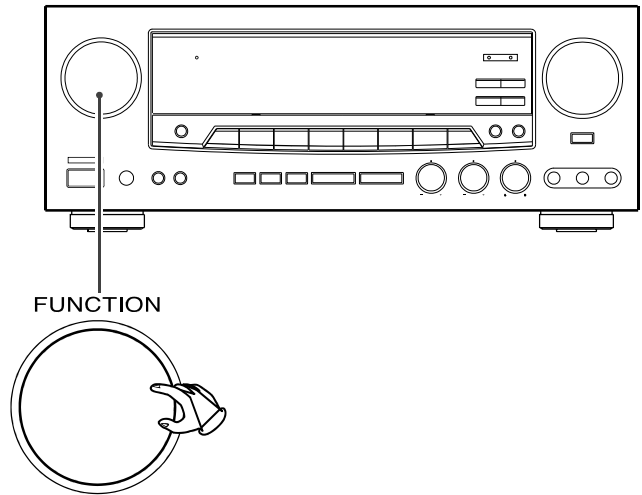

Tape Dubbing

(from TV/VIDEO 2, AUX/VIDEO 3 or DVD/CD to VCR/VIDEO 1)

- 1** Turn the FUNCTION (source) selector to select the VIDEO source (TV/VID 2, AUX/VID 3 or DVD/CD) to be recorded.
- 2** Play back the source (TV/VID 2, AUX/VID 3 or DVD/CD).
- 3** Operate VCR/VID 1 for recording.
Video/audio signals from the selected VIDEO source can be dubbed to VCR/VIDEO 1 only.

Note:

- < When tape dubbing is performed, be sure to connect the VCR/VID 1 OUT (analog audio output).
- < You cannot record video tapes from DVD discs.

Video Camera Connections

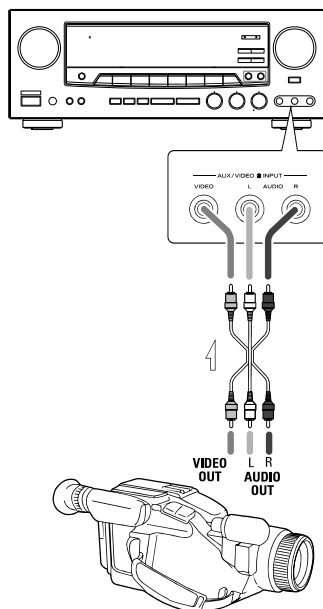

VCR, Video Camera Recorder, etc.

Connect the video camera recorder's AUDIO OUTPUT to the AUDIO (L)/(R) jacks and VIDEO OUT to the VIDEO jack of the AUX/VIDEO 3 INPUT.

S.A.V.E. (Second Audio Source for Video Editing) System

This feature lets you replace the sound from a VCR with sound from an AUDIO source such as CD during video signal dubbing.

- 1** Select the video source (TV/VID 2, AUX/VID 3 or DVD/CD) by turning the FUNCTION selector. Wait for more than 5 seconds and then select the audio source with the FUNCTION selector.
- 2** Operate the selected video component and audio component for playback, respectively.
- 3** Now you can watch the picture from the video component on the TV, and listen to the sound from the audio component through the speakers.
- 4** Operate VCR/VID 1 for recording.

The surround functions create a "live" atmosphere such as that experienced in movie theaters, stadiums and concert halls.

Select the appropriate surround mode according to the program source.

- < Note that surround speakers are needed for DTS/DOLBY DIGITAL/Dolby Pro LogicII Surround mode to function, and a center speaker is needed for the 3 Stereo mode to function.
- < It is recommended to use a center speaker when operating unit in DTS/DOLBY DIGITAL/Dolby Pro LogicII Surround modes.
- < When a Dolby Digital format signal is input, the surround mode automatically switches to the DOLBY DIGITAL mode.

This unit is provided with the following surround modes.

DTS (Digital Theater System)

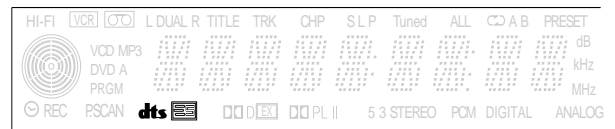
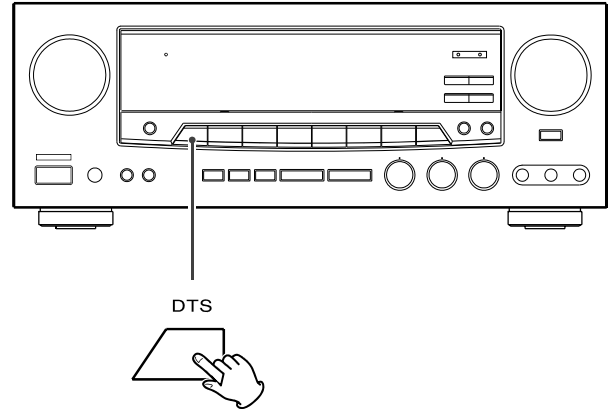

DTS MODE

(dts, Neo:6 Cinema, Neo:6 Music)

This mode is for DTS encoded source materials such as LASER DISC, CD, and DVD. Neo:6 is to some 2 channel signal source.

dts : This mode is enabled when playing source materials encoded in dts multi channel.

Playing multi-channel encoded 5.1 - channel dts sources provides five main audio channels (left, center, right, surround left and surround right) and Low Frequency Effect channel.

dts-ES decoding is not available in this mode.

The DTS mode cannot use when an analog input has been selected.

Neo: 6 Cinema, Neo:6 Music

This mode decodes 2-channel signals into 6-channel signals using high-accuracy digital matrix technology.

The DTS NEO:6 decoder has near-discrete properties in the frequency characteristics of the channels as well as in channel separation.

According to the signals to be played back, DTS NEO:6 uses either the NEO:6 CINEMA mode optimized for movie playback or the NEO:6 MUSIC mode optimized for music playback.

Notes:

- < Neo:6 mode is available to 2ch input signal which is encoded Dolby Digital or PCM format.
- < PCM-audio signals can be subjected to Pro Logic processing when the sampling frequency is 32kHz, 44.1 kHz or 48 kHz.

DOLBY DIGITAL Surround

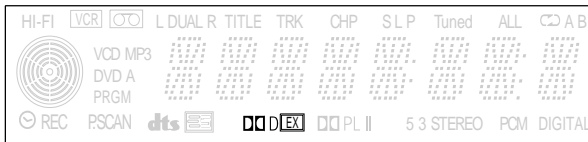
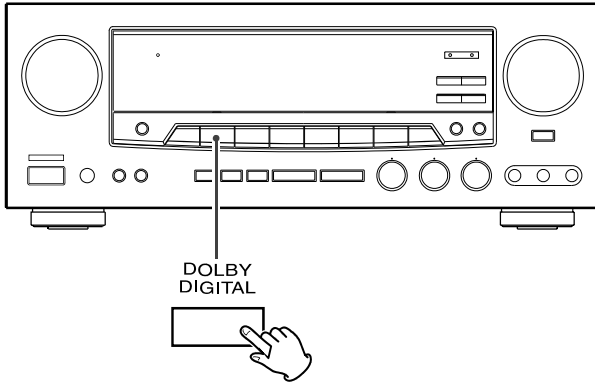

Dolby Digital EX

In a movie theater, film soundtracks that have been encoded with Dolby Digital surround EX technology are able to reproduce an extra channel which has been added during the mixing of the program.

This channel, called Surround Back, places sounds behind the listener in addition to the currently available front left, front center, front right, surround right, surround left and subwoofer channels.

This additional channel provides the opportunity for more detailed imaging behind the listener and brings more depth, spacious ambience and sound localization than ever before.

Dolby Digital EX is not available in the system without surround back speaker(s).

SURROUND MODE Button

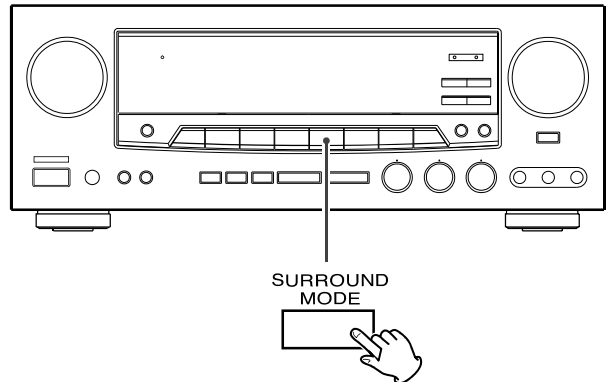

Surround mode changes as follows whenever you press this button.

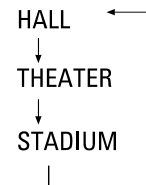

> DOLBY PRO LOGIC II Surround

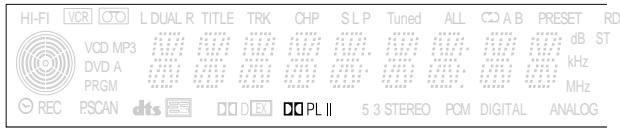

Dolby Pro Logic II brings the excitement of surround sound to any stereo mix, while making existing Dolby Surround mixes sound more like discrete 5.1 channels Surround sound.

Dolby Pro Logic II has below 3 modes.

Pro Logic II MUSIC

This mode provides 5.1 channel surround sound from conventional stereo sources, analog or digital, such as CD, tape, FM, TV, stereo VCR, etc.

Pro Logic II MOVIE

This mode provides 5.1 channel surround sound from Dolby surround encoded stereo movie sound tracks.

Pro Logic II EMULATION

This mode emulated original Dolby Pro Logic decoding.(3/1 surround) suit for Dolby Surround encoded stereo movie soundtracks.

Notes:

- < Pro Logic II mode is available to 2ch input signal which is encoded Dolby Digital or PCM format.
- < PCM-audio signals can be subjected to Pro Logic processing when the sampling frequency is 32kHz, 44.1kHz or 48 kHz.

> 3 STEREO

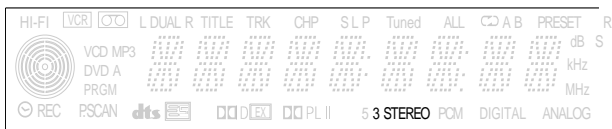

Front speakers receive rear (surround) speaker signals in addition to front speakers signals.

Center speaker works similarly to Dolby Pro Logic I mode.

This mode improves imaging without the use of rear speakers.

> HALL Surround

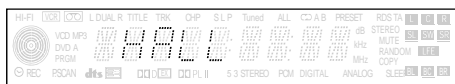

When playing recordings of live music, this mode provides a feeling similar to actually being in a concert hall.

When this mode is selected, the normal program source is directed to the main speakers and a reverberated sound is directed to the surround speakers.

This mode is suited to program sources which contain a large amount of reverberation.

> THEATER Surround



This mode provides a three dimensional effect similar to that of movie theater.

With this mode, you can enjoy a surround effect similar to Dolby Surround sound even when playing a video program which is not encoded with the Dolby Surround system.

> STADIUM Surround



The reverberation of this mode produces a sound field which recreates the sound of a stadium.

> STEREO

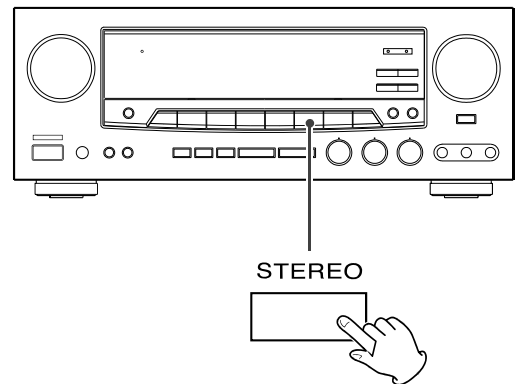

To switch the surround mode to stereo mode, press the STEREO button.

When DTS or DOLBY DIGITAL is selected, the surround sound is down mixed to 2 channel.

In this case, press the STEREO button once more to go back to the previous surround mode (DTS or DOLBY DIGITAL)..

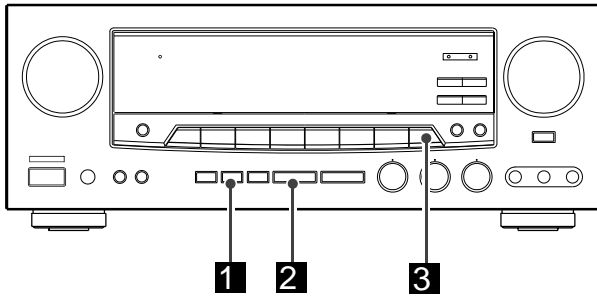

It is important to perform speaker configuration prior to using the surround sound decoder.

This allows the unit to sense the available speakers and automatically select decoding modes. It is possible to receive multi-channel surround sound without a center speaker, but for best results with Dolby Pro LogicII and Dolby Digital decoding, at least 5 speakers (Left, Center, Right, Left Rear and Right Rear) should be used.

1 Each press of the **SPEAKER CONFIGURATION**

button will change the desired Speaker Configuration shown on the display. (ex.: "FNT-LARGE", "FNT-SMALL", "CNT-LARGE", "CNT-NONE", "SUR-SMALL etc.)

When no action is taken for 5 seconds, the display returns to the normal mode.

2 Use the **ADJUST (▲/▼)** buttons to set the appropriate status.

3 **SUBWOOFER OUTPUT**

< **SUB-ON** : Choose if a subwoofer is used.

Low frequencies of 90Hz and below in the LFE channel and other selected channels are output to the subwoofer.

< **SUB-OFF** : Choose if no subwoofer is used.

Low frequencies of 90Hz and below in the LFE channel and other selected channels are distributed between the front L and R speakers.

Caution :

If the subwoofer selector is set to off, the LFE/Bass out frequencies are sent to the front speakers.

This can cause damage to small compact speakers when played at high volume

When the front speaker mode is selected small, You must selecte **SUB-ON**.

FRONT SPEAKER Mode:

- < **FNT-LARGE**: The mode to choose if a large speaker is installed. Front channels output is full range.
- < **FNT-SMALL**: The mode to choose when using compact speakers. When using small compact front speakers, it is recommended to connect a powered subwoofer to play the LFE/Bass out channel.

CENTER SPEAKER Mode:

- < **CNT-LARGE**: Use this mode with a large center speaker. The center channel's output is full range.
- < **CNT-SMALL**: Use this mode with a small center speaker. Bass frequencies below 90 Hz are output from the speaker selected by LFE/Bass Out.
- < **CNT-NONE (DTS/DOLBY DIGITAL/DOLBY PRO LOGICII, 3 STEREO mode only)**:
Use this mode if there is no center speaker. The center channel signal will be divided between the main L and R speakers.

SURROUND SPEAKER Mode:

- < **SUR-LARGE**: The mode to choose if a large speaker is used or if a subwoofer is connected in parallel. The rear channels output is full range.
- < **SUR-SMALL**: The mode to choose if small speakers are used. Frequencies of 90Hz and below are output to the speaker selected by LFE/Bass Out.
- < **SUR-NONE**: Select if no surround left and right speakers are connected.

SURROUND BACK SPEAKER Mode:

- < **BAC-LARGE**: Select if the surround back speakers are large sized.
- < **BAC-SMALL**: Select if the surround back speakers are small sized.
- < **BAC-NONE**: Select if the surround back center speakers are connected. (DTS/DOLBY DIGITAL mode only)

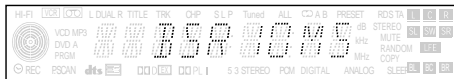
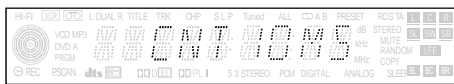
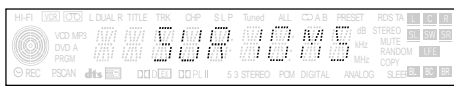
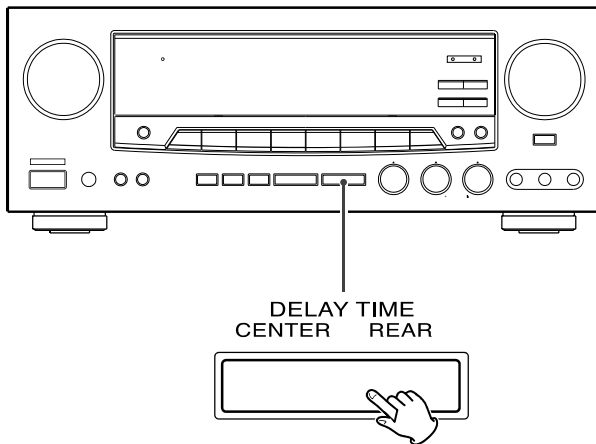

Delay Time

The delay time can be individually set for the Dolby Digital/Dolby Pro LogicII modes using the DELAY TIME (CENTER/REAR) buttons.

When you adjust the delay time in the Dolby Digital mode, an additional 15 ms is automatically added to the surround channels in the Dolby Pro LogicII mode. The current setting is shown on the display.

Delay Time Setting
Adjustable Range

DOLBY DIGITAL Mode:

- 0 ~ 5 ms in 1 ms step (CNT-Delay)
- 0 ~ 15 ms in 1 ms step (SUR-Delay)
- 0 ~ 20 ms in 1 ms step (BSR-Delay)

DOLBY PRO LOGIC II Mode(SUR-Delay)

- Music: 0 ~ 15 ms in 1 ms step
- Movie: 10 ~ 25 ms in 1 ms step
- Emulation: 10 ~ 25 ms in 1 ms step

In the surround modes, the sound from the rear speakers should be delayed slightly, relative to that from the front speakers.

The optimum delay time will depend on acoustic properties, whether the walls and furnishings reflect or absorb sound, etc. It is recommended that you try different delay times to obtain the best effect. The delay is digitally synthesized, for the highest sound quality with minimum noise and distortion.

The delay time can be set independently for each surround mode using the DELAY TIME buttons, with the current setting shown in the display.

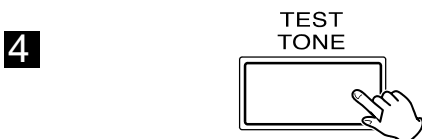
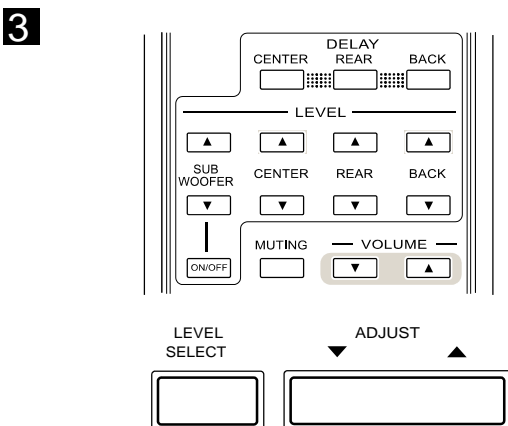
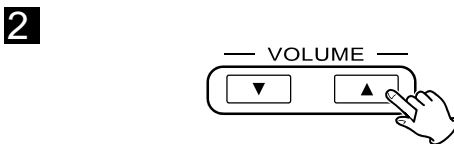
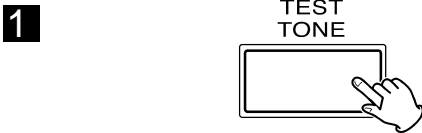
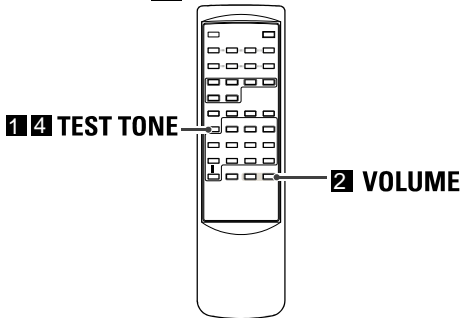
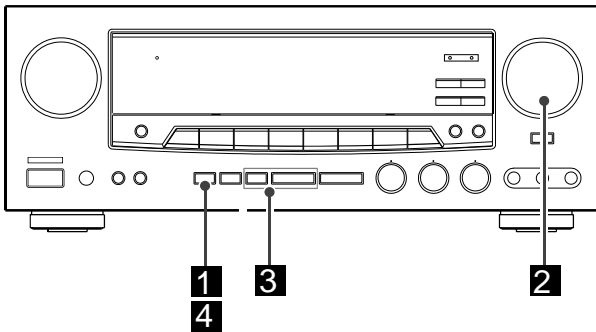

Balancing relative volume between speakers

The test tone function is useful to adjust the relative volume between speakers in DTS, DOLBY DIGITAL or DOLBY PRO LOGIC II mode.

Once the balance is set, you don't have to change the balance as long as the speakers aren't moved.

- 1** Press the TEST TONE button in DTS, Dolby Digital or Surround mode.

The test tone is emitted from each speaker in the following order at 2-second intervals.

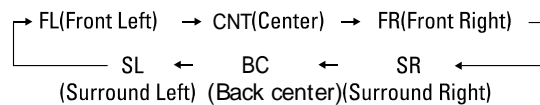

< Pro Logic II mode.

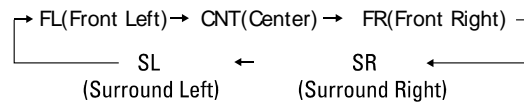

< 3-STEREO mode.

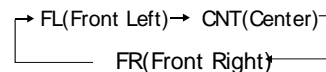

- 2** Adjust the master volume to the normal listening level.

- 3** Adjust the volume of center and rear speakers so that the test tone from each speakers sounds same.

Select a speaker by pressing the LEVEL SELECT button, and adjust the level by pressing the ADJUST button (▲/▼), or adjust the channel level directly by pressing the remote control unit (Center, Rear, Subwoofer, Back :▲/▼).

< The level of rear, center, subwoofer and Back can be adjusted in 1 dB steps from -10 dB to +10 dB.

- 4** When the setting is finished, press the TEST TONE button to stop the test tone.

Note :

< If certain speakers are not being used, (for example, no center speaker) the noise sequencer will automatically skip over that channel.

< Press the LEVEL SELECT, ADJUST button for more than 5 seconds to reset the level to its original setting.

To determine any problem with your receiver, always check the most obvious possible causes first. If any problem still remains after you have checked the items below, consult your nearest Eltax dealer.

Problem	Probable Cause	Remedy
Amplifier		
When listening to the music in stereo, left/right speakers sounds reversed.	Speakers are connected wrong.	After checking, if needed, reconnect.
Low hum or buzzer sound.	Power line of a fluorescent light is installed near this product.	Place this product as far away as possible from electric devices with interference.
Sound is only heard from one channel.	One of the input cords is disconnected.	Connect the input cords securely.
	The BALANCE control is set to one side.	Adjust the BALANCE control.
Sound cuts off during listening to the music or no sound even though power is ON.	Speaker impedance is less than prescribed for this unit.	After turning off the power and then turning it on again, reduce the volume or change to the correct 8 ohm speakers.
No sound.	A/B Speaker selectors are turned off.	Press the A or B speaker selector as applicable.
Low bass response.	Speaker polarity (+/-) is reversed.	Check all speakers for correct polarity.
Tuner		
An unusual hissing noise is heard when listening to the broadcast in stereo, but not heard when listening monaurally.	A slight noise may be heard because the method used for modulation of FM stereo broadcasts is different than that used for monaural broadcasts.	<ul style="list-style-type: none"> • Try reducing the treble sound by turning the treble controls. • Try changing the location, height and/or direction of the antenna. • Set the FM mode to monaural by pressing the STEREO/MONO button. (Note that the broadcast will then be heard as monaural sound). • If an indoor antenna is being used, change to an outdoor antenna. • Try using an antenna with more elements.
Noise is excessive in both stereo and monaural broadcasts.	Poor location and/or direction of the antenna.	
	Transmitting station is too far away.	
Sound is distorted and/or the volume level becomes low.	Broadcast signals are being disturbed.	
Excessive distortion in the sound of stereo broadcasts.	Speaker system connections are not correct.	
Surround Effects <Important :> The center and rear speakers only operate when the unit is set on a Surround Sound mode and the source material being played is recorded or broadcast in Dolby Digital EX, DTS/ES, Dolby Pro Logic I surround sound. Stereo broadcasts or recordings will produce some rear channel effects when played in a surround mode. However, mono sources will not produce any sound from the rear speakers.		
No sound from the Surround speakers.	SURROUND ON/OFF button is set to OFF.	Set the button to the desired surround mode position.
	Source being played is not recorded or broadcast in surround sound or stereo.	Use surround or stereo source.
	One or more rear speaker wires is not making good contact.	Check all rear speaker wires for good connection.
No sound from the center speaker.	SURROUND mode button is not set to DOLBY DIGITAL, DTS, DOLBY PRO LOGIC I or 3 STEREO.	Set the button to Dolby Digital EX, DTS/ES, Dolby Pro Logic I or 3 STEREO.
No sound from the surround back speaker	The surround back speaker cable connection is incomplete Surround mode is not EX/ES mode. Surround back = NONE has been selected in SPEAKERS Configuration.	Connect the cable correctly. Set surround mode EX/ES Make the correct setting.
No sound from the front speaker.	'Short pin's not insert EQ jack When speaker A and B is selected Simultaneously, but speaker B is Not connection.	Insert the 'short pin' Connect the speaker both A and B. Select speaker A only
Remote Control Unit		
Remote control not working.	The batteries are exhausted.	Replace with new batteries.
	The remote control unit is too far from the receiver or out of the effective range.	Operate the remote control unit within the effective range.

Amplifier Section

Output Power

Stereo Mode : 120W/CH
(1% THD 1KHz 8ohm DIN)
Surround Mode : 92W/CH
(1% THD 1KHz 8ohm DIN)

THD : 0.01%

DOLBY DIGITAL Mode:

Surround : 0 ~ 15 ms
Center : 0 ~ 5 ms
Back surround : 0 ~ 20 ms

DOLBY PRO LOGIC Mode (Surround):

Music : 0~5 ms
Movie : 10~25 ms
Emulation : 10~25 ms

Frequency Response:

*LINE: 10 Hz – 70 kHz, +1/ –3 dB

Signal-to-Noise Ratio:

*LINE: 100dB (IHF-A)

Tone Control:

BASS: ± 10 dB at 100 Hz
TREBLE: ± 10 dB at 10 kHz

Digital Audio Section

Sampling Frequency: 32 kHz, 44.1 kHz, 48 kHz, 96 kHz

DIGITAL Input Level/Impedance:

DIGITAL 1, 2 (OPTICAL): –15 dBm — –21 dBm
DIGITAL 3 (COAXIAL): 0.5 Vp-p / 75 ohms

FM Tuner Section

(Without notes 100.1 MHz, 65 dBf)

Tuning Range:

87.5 MHz – 108.0 MHz (50 kHz steps)

Usable Sensitivity (IHF):

Mono: 11.2 dBf

50 dB Quieting Sensitivity:

Mono: 15.3 dBf
Stereo: 38.5 dBf

Capture Ratio: 2.0 dB

Image Rejection Ratio: 45 dB

AM Suppression Ratio: 55 dB

Total Harmonic Distortion (1 kHz):

Mono: 0.2%
Stereo: 0.3%

Frequency Response: 30 Hz – 15 kHz, +1/ –1.5 dB

Stereo Separation (1 kHz): 40 dB

Signal-to-Noise Ratio:

Mono: 70 dB
Stereo: 65 dB

AM Tuner Section

Tuning Range:

522 kHz – 1,620 kHz (9 kHz steps)

Usable Sensitivity: 55 dB/m

Total Harmonic Distortion: 0.8% at 85 dB/m

Signal-to-Noise Ratio: 45 dB at 85 dB/m

Video Section

Input Sensitivity/Impedance: 1.0 Vp-p/75 ohms

Output Level/Impedance: 1.0 Vp-p/75 ohms

General

Power Requirements:

230 V AC, 50 Hz

Power Consumption:

320W

AC Outlets:

Switched x 1, 100 W max.

Dimensions (W x H x D)

435 x 165 x 350 mm (17-1/8" x 6-1/2" x 13-3/4")

Weight (net): 12Kg

Standard Accessories:

AM Loop Antenna x 1

FM Antenna x 1

Remote Control Unit x 1

Owner's Manual x 1

* LINE means CD, TAPE, VCR/VID 1, TV/VID 2, AUX/VID 3 and DVD/CD.

< Improvements may result in specifications and features changing without notice.

< Illustrations may differ slightly from production models.

